

FUEL SYSTEM

**GROUP
10**

Page

MOTORCRAFT CARBURETTOR

Service adjustments	10-11
Automatic choke — overhaul ..	10-14
Automatic choke hose — replace	10-14
Carburettor — remove and install	10-15
Carburettor — clean — inspect — adjust	10-16
Carburettor needle valve — replace	10-18

WEBER-2V CARBURETTOR

Description	10-19
Service adjustments	10-21
Automatic choke — overhaul ..	10-27
Carburettor — remove and install	10-25
Carburettor — clean — inspect — adjust	10-26

AIR CLEANERS AND FUEL PUMPS

Description and operation	10-29
Remove and install	10-32
Fuel pump test	10-33
Fuel pump clean	10-33
Fuel pump — remove and install	10-33

SPECIFICATIONS	10-34
--------------------------------	-------

Page

General description.. .. .	10-1
Diagnosis and testing	10-1
Accelerator cable — adjust	10-1
Accelerator cable — replace	10-2
Choke cable — replace	10-2
Accelerator shaft — remove and install	10-2
Evaporative emission control systems	10-3

GENERAL DESCRIPTION

The fuel system comprises a fuel tank, a mechanical fuel pump (incorporating a nylon mesh filter), and a down draft carburettor. A single venturi carburettor is fitted to 1.6 litre, and a dual venturi carburettor to 2.0 litre engines.

Fuel Tank Sedan

This fuel tank is located under the rear floor pan and is held in position by two straps. The filler neck protrudes through the back panel and is covered by the spring loaded licence plate frame.

Van

The fuel tank is located beneath the load space floor panel and is held in position with straps. The filler neck protrudes through the right hand quarter panel.

Sedan and Van

The combined fuel outlet and tank sender unit is located on the front face of tank and can be removed with the fuel removed and the tank in-situ.

Fuel Tank

Fuel tank ventilation is by means of the evaporative emission system (see page 10-3).

The 2.0 litre has a fuel return pipe located in the sender unit flange.

Fuel Pump

The mechanical type fuel pump is mounted on the side of the cylinder block and incorporates a nylon mesh filter located in the pump top housing.

The pump is a sealed unit and service is limited to cleaning of the filter.

Carburettor

1.6 litre engines are fitted with a Motorcraft single venturi carburettor having a manual choke on manual transmission and an automatic choke on automatic transmission.

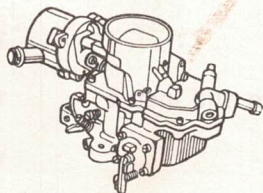

2.0 litre 2V engines have a sequential dual venturi Weber carburettor with an auto-choke. Also this carburettor has an anti-stall device, and is equipped with a fuel return line.

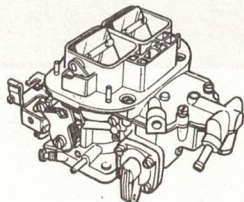
**Air Cleaner**

The design of the air cleaner varies with the type of carburettor used, but all have a paper element.

The air inlet temperature is thermostatically controlled on all models.

PRINCIPLE OF OPERATION

Throttle control is by means of a cable which is actuated by an accelerator shaft inside the passenger compartment.

Fuel is drawn from the tank by the engine driven diaphragm type fuel pump, through a nylon fuel line.

As the level in the fuel tank fluctuates, the sender unit float rises or falls and alters the resistance of the rheostat from which it is pivoted. The bi-metal type fuel gauge is actuated by this variation in voltage.

The fuel passes through the fuel pump, which incorporates a nylon screen filter to the carburettor.

On 2.0 litre engines with Weber 2V carburettor a return fuel line is fitted between the carburettor and the fuel tank.

FUEL SYSTEM GENERAL**DIAGNOSIS AND TESTING****FUEL TANK, LINES AND FILTER**

Water and dirt that accumulate in the fuel tank can cause a restricted fuel line or filter and malfunction of fuel pump, or carburettor. Condensation, which is the greatest source of water entering the fuel tank, is formed by moisture in the air when it strikes the cold interior walls of the fuel tank.

Two fuel filters are used in the system; one is integral with the pump and the other on the end of the fuel tank pick-up tube. An additional filter is located in the inlet port of Weber carburettors fitted to 2.0 litre engines. The pick-up tube filter is non-serviceable.

If the accumulation of sediment in the tank filter is excessive, the fuel tank should be removed and flushed, and the line from the fuel pump to the tank should be blown out and a new filter installed.

Leakage in the fuel inlet line can cause low vacuum, and volume conditions, and loss of fuel.

A restricted fuel tank vent system can cause low fuel pump pressure and volume and may, in some instances, result in collapsed inlet hoses or a collapsed fuel tank.

See Evaporative Emission Control System.

FUEL PUMP

Incorrect fuel pump pressure and low volume (flow rate) are the two most likely fuel pump troubles that will affect engine performance. Low pressure will cause a lean mixture and fuel starvation at high speeds and excessive pressure will cause high fuel consumption and carburettor flooding. Low volume will cause fuel starvation at high speeds.

CABLE — ACCELERATOR — ADJUST

1. Open bonnet and fit fender covers.
2. Remove air cleaner assembly.
3. Wind in cable adjusting sleeve, Fig. 1. Locate throttle in wide open position and jam in this position with a suitable block of wood.
4. Wind back adjusting sleeve to a point where carburettor linkage is just in fully open position.
5. Release throttle pedal and reapply checking that wide open throttle is just achieved, readjust if necessary.
6. Refit air cleaner assembly.
7. Remove fender covers and close bonnet.

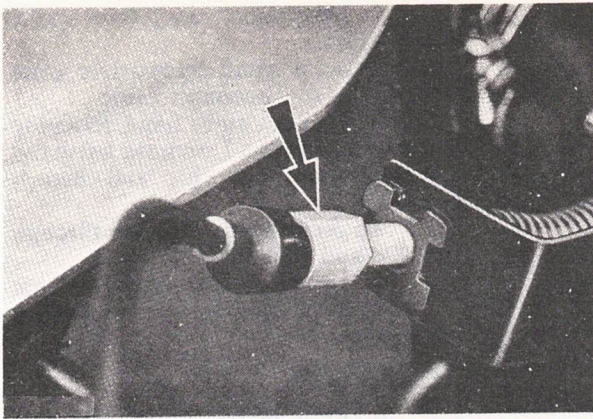

Fig. 1. Accelerator cable adjusting sleeve.
1.6 litre shown.

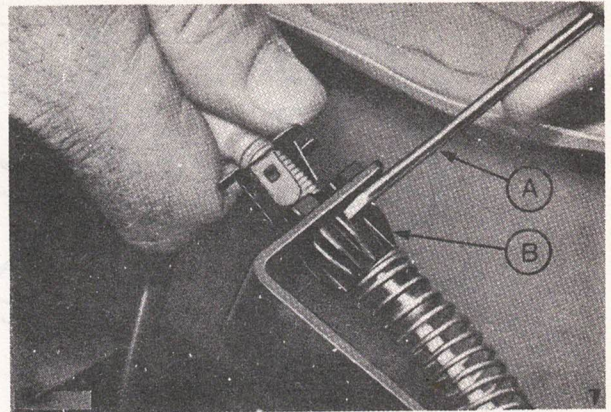

Fig. 3. Disconnecting cable from bracket.
A—Electricians screwdriver.
B—Cable to bracket retaining catch.
1.6 litre shown.

CABLE — ACCELERATOR — REMOVE AND INSTALL

To Remove

1. Open bonnet and fit fender covers.
2. Disconnect inner cable at carburettor and outer cable from bracket.

To detach cable from bracket, firstly prise out retaining clip, Fig. 2, and twist out cable pressing the sides of retaining clip, Fig. 3.

3. Remove parcel shelf assembly.
4. Disconnect accelerator cable from pedal.

Using a small screwdriver prise off cable retaining clip and disconnect cable from shaft.

5. From engine compartment unclip cable from bulkhead and detach.

To Install

6. Route cable through engine

rear bulkhead and clip outer cable to bulkhead.

7. Reconnect cable to pedal shaft and refit securing clip.

8. Refit parcel shelf.
9. Clip outer cable to bracket and reconnect inner cable to carburettor shaft.

10. Adjust accelerator cable.
11. Remove fender covers and close bonnet.

CABLE — CHOKE CONTROL — REMOVE AND INSTALL
1.6 litre manual only

To Remove

1. Open bonnet and fit fender covers.
2. Remove air cleaner assembly.
3. Disconnect cable from carburettor and air cleaner mounting stay.
4. From under dash remove cable lock nut and pull out cable assembly, Fig. 4.

To Install

5. Thread cable through panel and route as shown in Fig. 5.

6. Secure retaining nut.
7. Reconnect cable to carburettor and air cleaner mounting stay and adjust.

To adjust pull inner cable out from dash approximately 6 mm (¼ in.), with choke plate fully open take out all the slack from inner cable and lock up clamp screws. Push choke fully home.

8. Refit air cleaner.
9. Remove fender covers and close bonnet.

ACCELERATOR SHAFT — REMOVE AND INSTALL

To Remove

1. Open bonnet and fit fender covers.
2. Remove right hand parcel shelf, Fig. 6. Secured by two screws and two pegs.

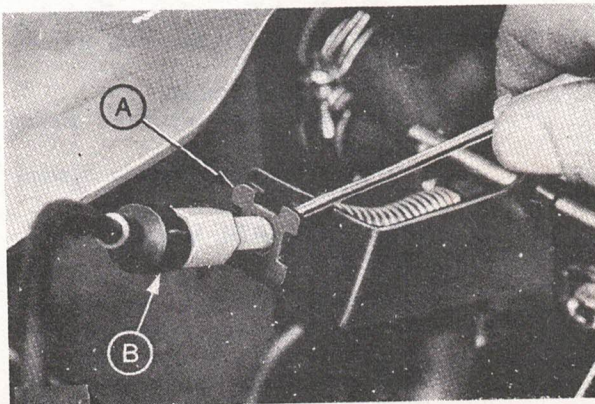

Fig. 2. Removal of accelerator cable retaining clip.
A—Cable retaining clip.
B—Accelerator cable.
1.6 litre shown.

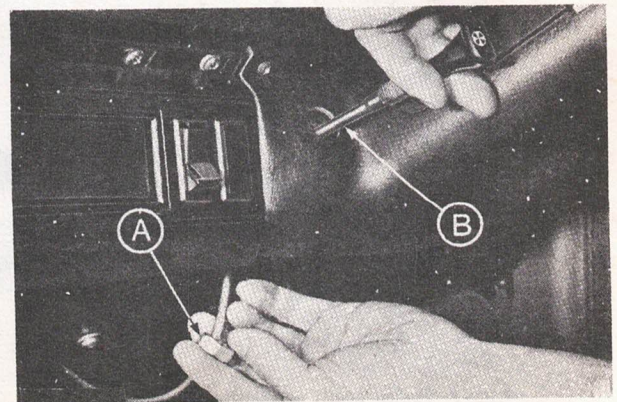

Fig. 4. Removal of choke cable from dash.
A—Choke cable lock nut.
B—Choke cable.
1.6 litre manual only.

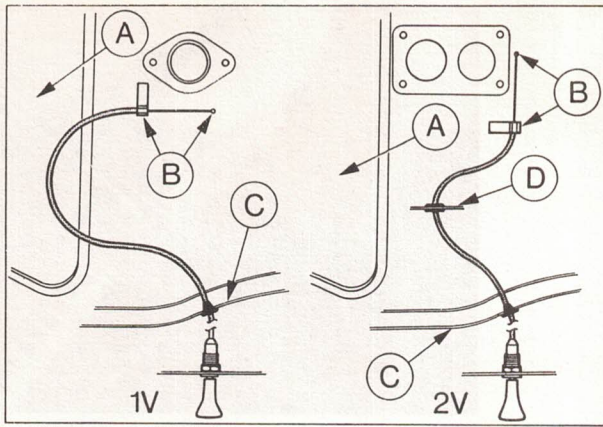

Fig. 5. Choke cable routing. 1.6 litre manual.

- A—Rocker cover.
- B—Cable to carburettor securing points.
- C—Dash panel.
- D—Throttle bracket.

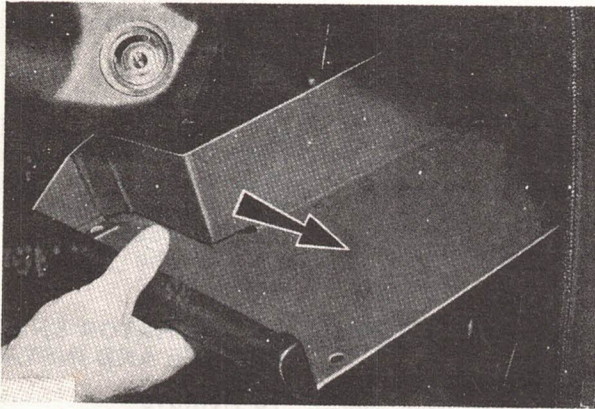

Fig. 6. Removal of right hand parcel shelf.

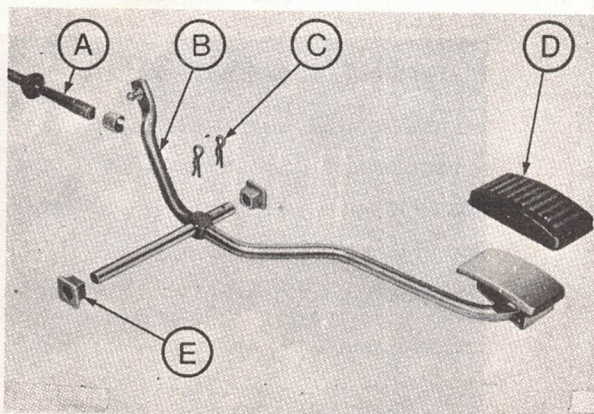

Fig. 7. Pedal shaft assembly (RHD).

- A—Accelerator cable.
- B—Accelerator shaft.
- C—Circlip.
- D—Pedal rubber.
- E—Mounting bush.

3. Disconnect accelerator cable at shaft.

Using a small screwdriver prise off clip to disconnect cable.

4. Pull out right hand retaining clip 'C' in Fig. 7. remove left hand mounting bush 'E', and detach shaft.

To remove bush, rotate through 90° and pull out.

5. Unclip pedal rubber from assembly and detach remaining circlip.

To Install

6. Refit pedal rubber and left hand circlip to shaft.

7. Position pedal shaft, refit left mounting bush and right hand circlip.

8. Reconnect accelerator cable to shaft.

9. Adjust accelerator cable.

10. Refit parcel shaft.

11. Remove fender covers and close bonnet.

EVAPORATIVE EMISSION CONTROL SYSTEMS

Approximately 20% of overall vehicle emissions consist of petrol vapors which escape from the fuel tank and carburettor. These evaporative losses occur not only when the vehicle is operating, but also when it is parked. In fact most fuel vapors are lost when the vehicle is parked.

This condition has been eliminated by closing the openings in the fuel system that are vented to atmosphere ... thus providing a sealed fuel system. With such a system, fuel vapors are trapped and directed to the engine for burning in the normal combustion process.

The Ford Evaporative Emission Control System is made up of three basic systems;

Fill Control System

Pressure and Vacuum Relief System

Vapor Vent and Storage System

FILL CONTROL VENT SYSTEM

The Fill Control vent system provides positive control of fuel height during fill operations by filler neck design and/or vent lines from the filler neck to the fuel tank. (See Figs. 8, 9, 10 and 11). This vent system is designed to permit an approximate 10 to 15 per cent volume void or space when the tank

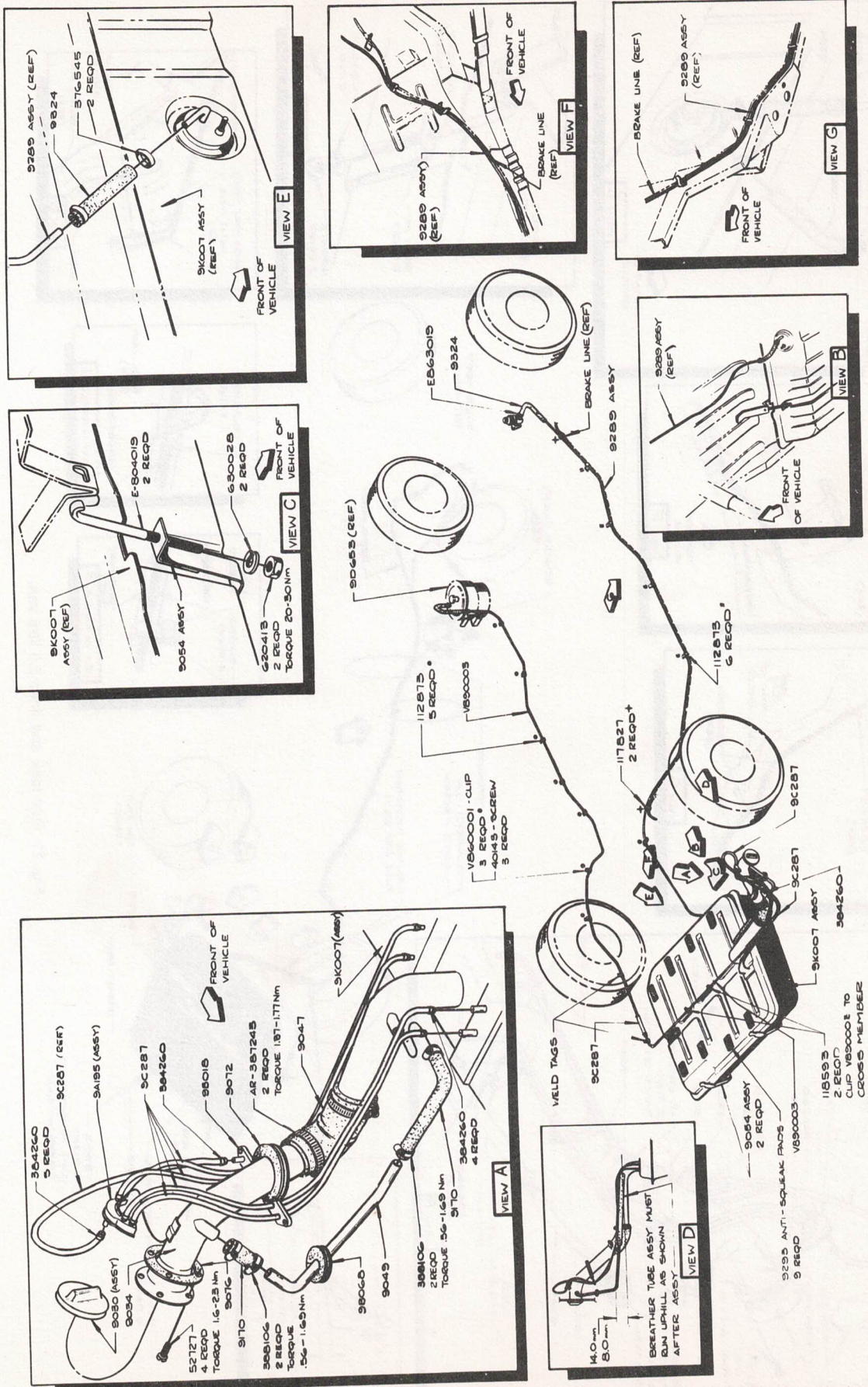

Fig. 10. Fuel tank and lines 1.6 litre van.

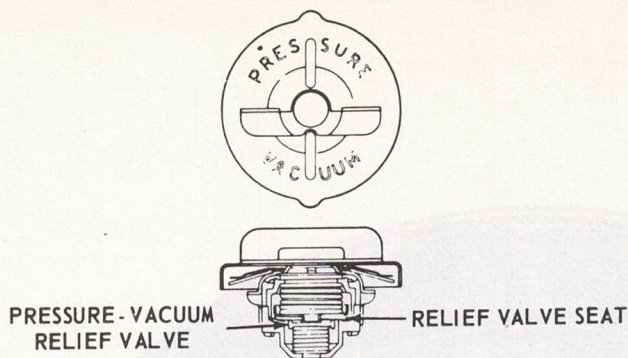

Fig. 12. Fill cap (pressure-vacuum relief design).

is filled to capacity. This space allows for heat expansion of the fuel, as well as aiding the function of the vapor vent lines in the tank.

PRESSURE AND VACUUM RELIEF SYSTEM

The pressure and vacuum relief system functions through the use of a sealed cap (Fig. 12) with a built in pressure and vacuum relief valve. Under normal operating conditions, the valve opens to relieve pressure when it exceeds 5.2 to 8.6 kPa (3/4 to 1 1.4 psi).

Conversely, when the fuel tank vacuum reaches 12.7 mm (1/2 inch) of mercury maximum, the valve opens and allows air to enter the system.

The fill cap functions as a check valve under normal operating conditions to allow air to enter the tank as the fuel is used while preventing fuel vapors from escaping through the cap. The pressure relief valve will only function if a malfunction occurs in the vapor lines between the fuel tank and the carbon canister.

Each venting system has a restriction with a 1.27 mm (0.050") orifice in the vapor line to minimise the possibility of raw fuel reaching the carbon canister.

The orifice is located in the vent pipe at the fuel tank.

VAPOR VENT AND STORAGE SYSTEM:

Figs. 8, 9, 10, 11.

The vapor vent system consists of a vapor space above the fuel surface in the fuel tank to allow adequate breathing space for the vapor. The fuel vapors trapped in the sealed fuel tank are vented through the orifice in the vapor line. The vapors are stored in the carbon canister

until they are purged into the engine for consumption.

On Escort vehicle lines a single fuel tank vapor outlet pipe is located in a position in the fuel tank that is always clear of liquid fuel under all vehicle operating attitudes.

CARBON CANISTER:

Figs. 13-14.

This unit, located in the engine compartment, contains a quantity of activated carbon for storage of fuel vapors.

In operation, fuel vapors are routed to the canister from two sources, these are:—

The Fuel Tank

The Carburettor Fuel Bowl (on 1.6 litre IV carburettors only. 2.0 litre 2V carburettors are internally vented and the carburettor pipe on the canister is plugged.)

On engine start-up, the vapor is purged out of the canister through the air outlet hose to the air cleaner then through the carburettor and into the combustion chamber where the vapors are consumed in the normal combustion process.

On engine shut-down, vapor in the carburettor fuel bowl is vented back into the canister for storage until the engine is restarted ... and the process is repeated.

SERVICE PROCEDURES:

Servicing of the evaporative emission control system, other than inspection for tank or fuel line leaks and damaged parts, is limited to ensuring lines are not kinked and the fill cap is functioning. Fill cap damage or contamination rendering the pressure-vacuum relief valve inoperative may result in deformation of the fuel tank.

Make sure that the correct fill cap is used and that it is in working order.

Component parts of the evaporative emission control system, except the fuel tank and lines, are not subject to repair. Malfunctioning or damaged parts should be removed and replaced with new parts.

Periodic maintenance at specific intervals (Refer to the Maintenance Schedule Group 19) is limited to checking the system for visible damage and checking the tightness of the hose clamps.

The carbon canister is good for the life of the vehicle, however the canister must be replaced if punctured, subjected to crushing, corrosion or contamination by oil, fuel or water.

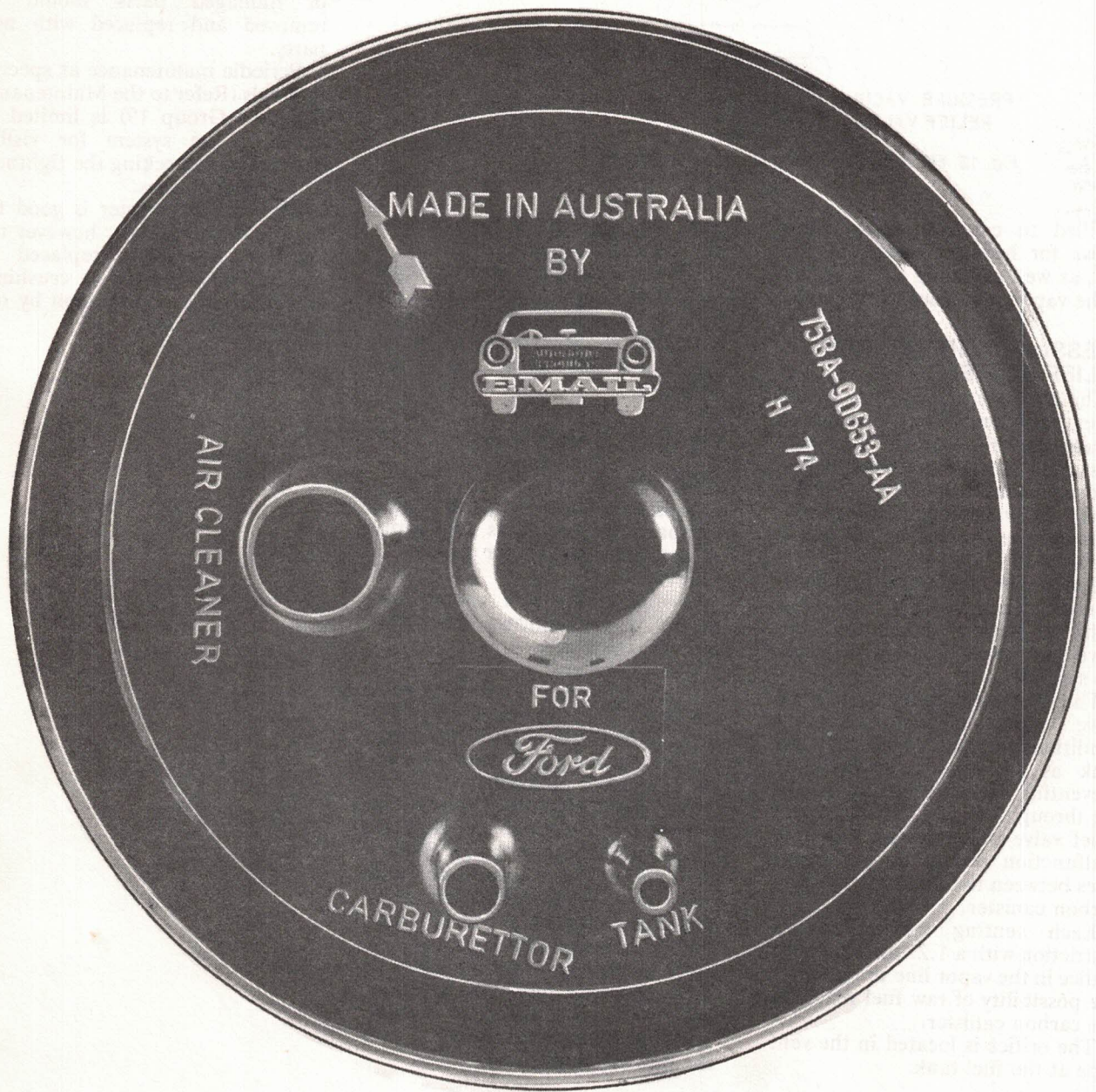

Fig. 13. Carbon canister hose connections.

MOTORCRAFT IV CARBURETTOR

CARBURETTOR — ADJUST

When carrying out adjustments requiring the use of a C. O. Meter it is essential that an instrument of the **non dispersive infra red** type be used. The thermal conductivity type meter found in most service shops is not accurate enough to give the required carbon monoxide readings.

For all operations carried out on the vehicle the bonnet is open and fender covers are fitted.

CURB IDLE SPEED AND CO LEVEL SETTING PROCEDURE — 4 CYLINDER ENGINES (1.6 litre — for ADR 27A)

Important: Whenever idle speed requires adjustment — Co level must be checked, and adjusted to specification if required.

1. PRE-TEST PREPARATION

Before commencing an idle check, ensure that:

- (a) the engine temperature gauge is not reading above normal, and the engine has not been idling for more than 10 minutes.
- (b) initial timing is set to specification.
- (c) the air cleaner is fitted correctly and the element is clean.
- (d) all vacuum hoses are correctly fitted.
- (e) air conditioning (where applicable) is off.
- (f) a calibrated tachometer reading in increments of 20 rpm is available.

(g) the CO meter is on, warmed up and calibrated.

2. ENGINE WARM UP

(a) If the engine is not already at normal operating temperature start the engine and allow it to idle until the thermostat opens.

Note: If the vehicle is fitted with a manual choke ensure that the choke is fully off in the shortest possible time.

(b) Drive the vehicle for 3 kilometres at moderate speed. Ensure that the choke is fully off.

NOTE: THIS 3 KILOMETRE DRIVE IS ESSENTIAL TO STABILIZE ENGINE TEMPERATURE PRIOR TO CHECKING IDLE CO LEVEL.

3. CURB IDLE SPEED AND CO CHECK AND ADJUST- MENT

(a) After returning from the 3 kilometre drive **do not** switch off the engine. **THE ENGINE MUST IDLE FOR 5 MINUTES BEFORE CO READINGS ARE TAKEN AND MUST NOT BE STOPPED DURING THIS PERIOD.**

During this period:—

- (i) Connect the tachometer.
- (ii) Connect the CO meter according to the manufacturer's instructions.
- (iii) Clamp the hose from the carburettor to the deceleration valve.

Note: This precludes possible erroneous readings caused by faulty deceleration valve operation. The deceleration valve cannot be correctly adjusted until idle speed and CO level have been set.

(b) After the 5 minute idle period has elapsed, increase the engine speed to 3000 rpm and maintain for 30 seconds. Allow the engine to return to idle for 10-20 seconds to enable the meter reading to stabilize and then check the idle speed and CO level in neutral gear.

(c) If the idle speed or CO level is not to specification adjust the idle mixture screw and/or the idle speed screw to obtain the required settings.

(d) Increase the engine speed to 3000 rpm and maintain for 30 seconds.

(e) Allow the engine to return to idle for 10-20 seconds to enable the meter reading to stabilize.

(f) Recheck idle speed and CO level to specification.

(g) If further adjustment is required repeat operations (c) to (f) until the correct specifications are achieved.

CAUTION: If total idle time exceeds 12 minutes the engine temperature must be restabilized by driving the vehicle for a further 3 kilometres and then allowing the engine to idle for 5 minutes before continuing adjustment.

(h) When the correct settings have been achieved remove the clamp from the deceleration valve hose and disconnect the tachometer and CO meter.

MANUAL CHOKE — FAST IDLE — CHECK AND ADJUST

1. Warm up engine to normal operating temperature.
2. Remove air cleaner assembly.
3. Check choke plate pull down. Described on page 10-13.

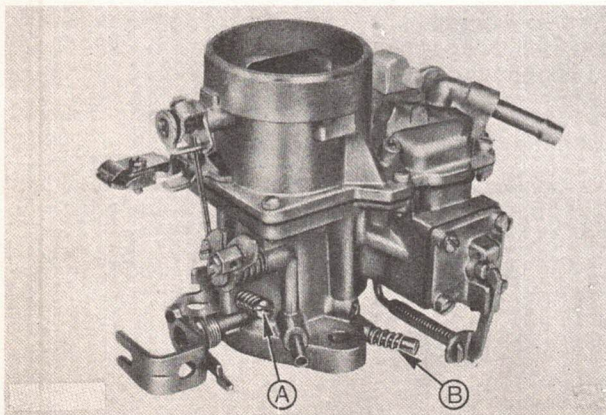

Fig. 15. Motorcraft manual choke carburettor.
A—Idle adjusting screw.
B—Mixture adjusting screw.

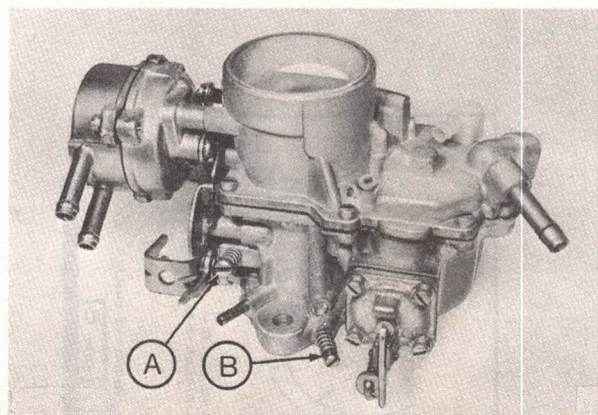

Fig. 16. Motorcraft auto-choke carburettor.
A—Idle adjusting screw.
B—Mixture adjusting screw.

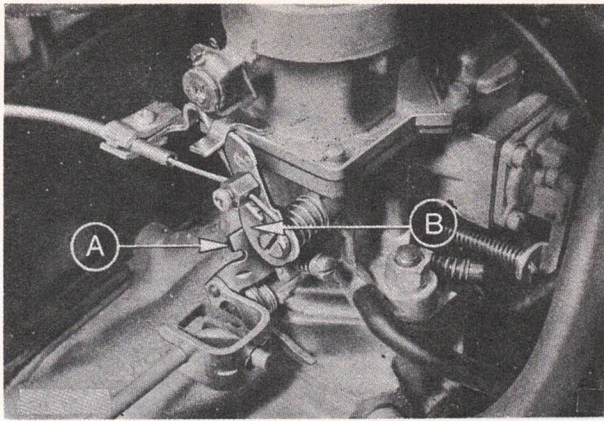

Fig. 17. Manual choke, fast idle adjustment.
A—Adjusting tag.
B—Fast idle cam.

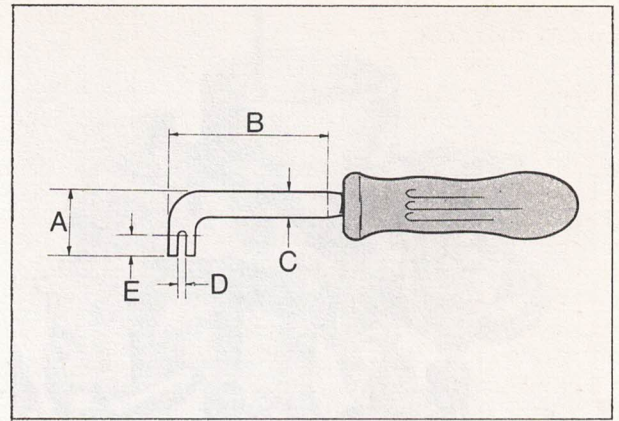

Fig. 19. Special tool for fast idle adjustment.
A—25 mm (1.0 in.)
B—50 mm (2.0 in.)
C—10 mm (0.38 in.)
D—2.5 mm (0.1 in.)
E—8.0 mm (0.32 in.)

4. Connect tachometer to engine as per manufacturers' instructions.

5. Manually hold choke plate fully open and operate choke mechanism as far as possible without altering choke plate position. This will be approximately a third of the total choke travel.

6. Fully operate choke mechanism, ensure choke plate is open, start engine and record r.p.m. Refer Specifications.

7. Stop engine and adjust as necessary by bending tag down in Fig. 17.

8. Recheck fast idle and readjust if required as described in sub-operations 6 and 7.

Refit air cleaner assembly.

AUTOMATIC CHOKE — FAST IDLE — ADJUST

1. Remove air cleaner assembly.
2. Start engine and check and adjust fast idle as necessary.

3. Run up engine to normal operating temperature. Stop engine and connect a tachometer to engine. Open throttle and locate fast idle cam in the fast idle position ('V' mark on the cam to line up with throttle lever.) Release throttle to hold cam in this position, Fig. 18.

NOTE: Check that choke plate is fully open, if not then either the engine is not at normal operating temperature or auto-choke is faulty. Start engine and record r.p.m. and adjust as necessary by bending tag on throttle lever.

To bend tag either use a pair of pliers or to make adjustment easier

make up a special tool to the dimension shown in Fig. 19.

4. Refit air cleaner assembly.

AUTOMATIC CHOKE — ADJUST

IMPORTANT NOTE: If mechanic is inexperienced in auto-choke repair then removal of complete carburettor before attempting the following adjustments is advisable.

1. Remove air cleaner assembly.

2. Remove three screws and pull off automatic choke housing and spring assembly, swing clear of carburettor and detach sealing gasket.

3. Check and adjust 'V' mark setting as required.

Fit an elastic band to choke plate lever and position band so that it holds the choke plate closed. Open

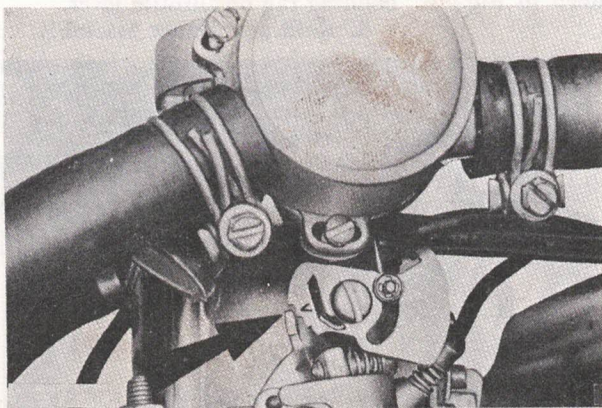

Fig. 18. Auto-choke mechanism set in fast idle position. Fast idle adjusting tag arrowed.

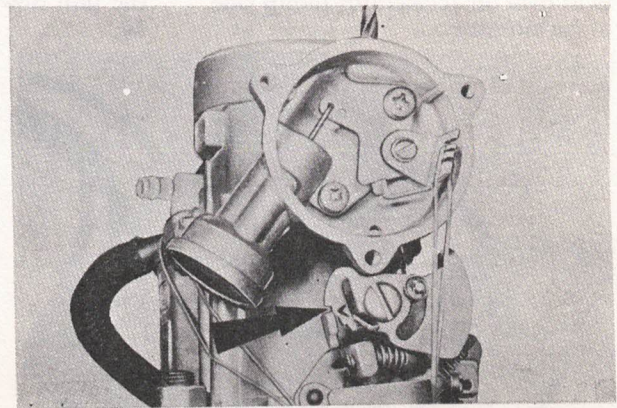

Fig. 20. "V" mark on cam lines up with throttle lever establishing correct "V" mark setting.

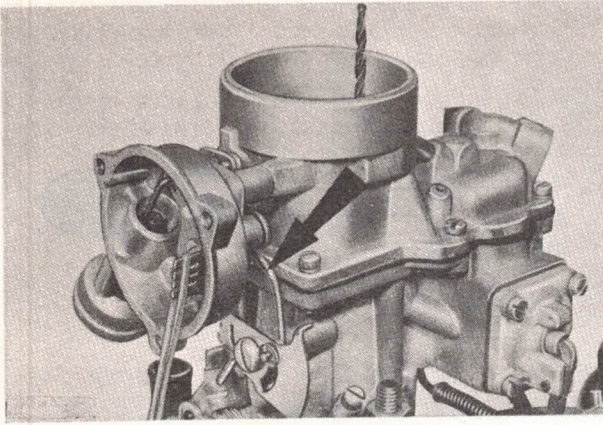

Fig. 21. "V" mark setting adjustment carried out by bending control rod shown.

throttle to allow the choke plate to fully close and release throttle.

Position a gauge rod or twist drill of correct size between the choke plate and air horn on accelerator pump side of carburettor. (Refer to Specifications.) Partially open throttle to allow fast idle cam to drop into its operating position and check that the 'V' mark on the cam lines up with the throttle lever, Fig. 20.

Adjustment is carried out by bending the choke control rod. Note that the control rod is located at the end of the slot in the fast idle cam when the check or adjustment is being carried out, Fig. 21.

4. Check and adjust de-choke.

With choke plate still held in the fully closed position, fully open throttle. The choke plate will de-choke just before full throttle. Adjustment is checked by measuring between the choke plate and air horn, with a gauge rod or twist drill on accelerator pump side of carburettor.

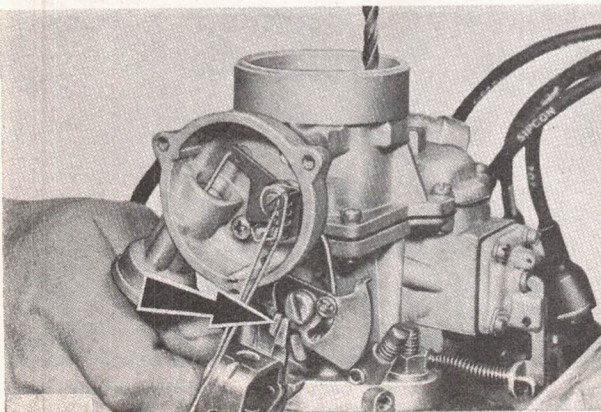

Fig. 22. De-choke adjustment. Adjusting tag marked.

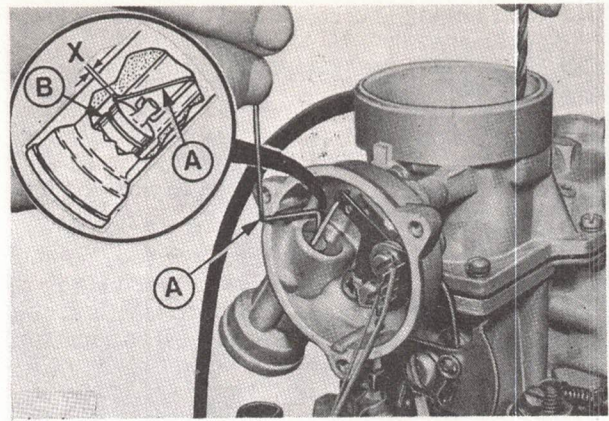

Fig. 23. Vacuum pull down adjustment.

A—One mm rod.

B—Vacuum piston.

Dimension X—One mm.

Adjust by bending de-choke lever on the fast idle cam, shown in Fig. 22.

NOTE: Care must be taken to ensure that the gauge rod is not dropped down into inlet manifold.

5. Check and adjust vacuum choke plate pull down.

Ensure rubber band is still holding choke mechanism in the fully closed position. Partially open throttle and choke mechanism. Insert a 1 mm (0.04 in.) rod in the slot located inside front edge of piston bore, refer Fig. 23. and release choke mechanism and throttle to allow piston to trap the rod. Measure gap between choke plate and air horn on accelerator pump side with a gauge rod or twist drill.

NOTE: Most paper clips measure 1 mm in diameter and are suitable for this operation.

Check diameter first.

Adjust as required by bending the pull down lever shown in Fig. 24.

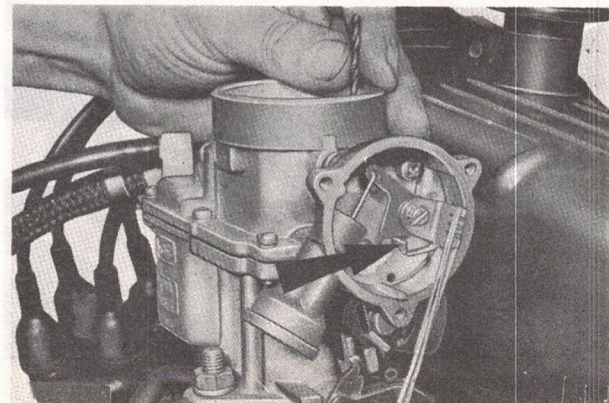

Fig. 24. Vacuum pull down adjustment tag.

6. Remove elastic band, position gasket and refit choke housing and spring assembly.

Connect choke spring into specified slot on operating link. (refer specifications to ascertain correct slot.) Position housing and loosely fit three retaining screws. Rotate housing till mark on spring housing lines up with centre mark on auto-choke housing. Lock up three screws, Fig. 25.

7. Start engine and check and adjust fast idle as necessary.

Run up engine to normal operating temperature and connect a tachometer. Switch off. Open throttle and locate fast idle cam in the fast idle position. ('V' mark on the cam to line up with throttle lever.) Release throttle to hold the cam in this position, Fig. 26.

NOTE: Check that choke plate is fully open, if not then either the engine is not at normal operating temperature or auto-choke is faulty. Start engine and record r.p.m., adjust as necessary by bending tag on throttle lever.

8. Refit air cleaner assembly.

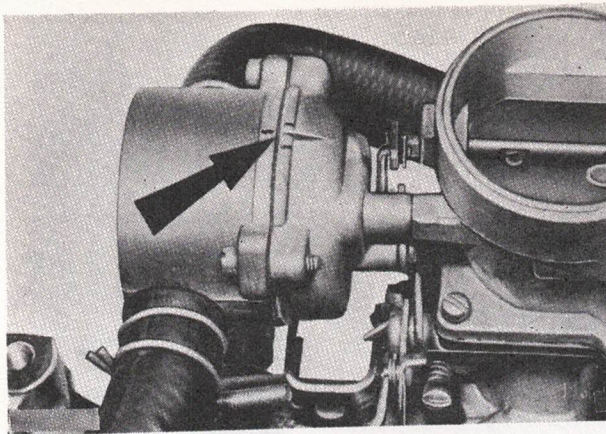

Fig. 25. Alignment marks for auto-choke housing.

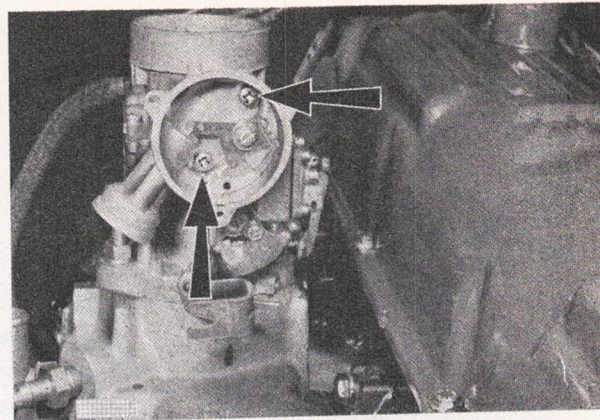

Fig. 27. Choke housing securing screws.

AUTOMATIC CHOKE — OVERHAUL

1. Remove air cleaner assembly.
2. Remove three screws, detach end housing and bi-metal spring assembly and swing clear of carburettor. Remove housing gasket.
3. Remove two screws securing auto-choke body to carburettor, Fig. 27.
4. Remove a single screw securing choke linkage to operating spindle and detach assembly, Fig. 28.
5. Remove a single screw, detach choke operating spindle and pull out vacuum piston, linkage, Fig. 29.
6. Clean and inspect auto-choke components.
Checking for wear or damage. Ensure that all components are clean and dry.
NOTE: Lubricant must **not** be used on reassembly.
7. Reassemble vacuum piston, operating spindle and operating linkage, Fig. 29.

Ensure that the plastic sleeve 'F' is refitted to the spindle 'B' when reassembling unit.

8. Reconnect auto-choke linkage to spindle, position main body and secure.

Ensure that the sealing rubber ('A' in Fig. 29.) is correctly located between the main choke body and the carburettor when installing unit.

9. Check and adjust 'V' mark setting as required.

10. Check and adjust de-choke setting.

11. Check and adjust vacuum pull down.

12. Refit choke housing and bi-metal spring assembly.

With a new gasket connect choke bi-metal spring into the specified slot on choke operating link, 'C' in Fig. 29. (Refer Technical Data to ascertain correct slot.) Place outer housing in position and loosely fit three retaining screws. Rotate housing till the mark on spring housing lines up with the centre mark on auto-choke housing. Lock up three screws, Fig. 25.

13. Start engine and check and adjust fast idle as required.
14. Refit air cleaner assembly.

HOSE AUTOMATIC CHOKE — REPLACE

- Remove air cleaner assembly.
1. Remove engine splash shield if fitted.
 2. Partially drain cooling system.
 3. Disconnect bottom hose at radiator and allow to drain.
 4. Disconnect hose at both ends and detach.

To Install

5. Transfer clips to new hose.
6. Position and reconnect hose.
7. Refill cooling system with specified water-anti-corrosion solution.
8. Refit engine splash shield if fitted.
9. Refit air cleaner assembly.
10. Start engine and check for leaks.

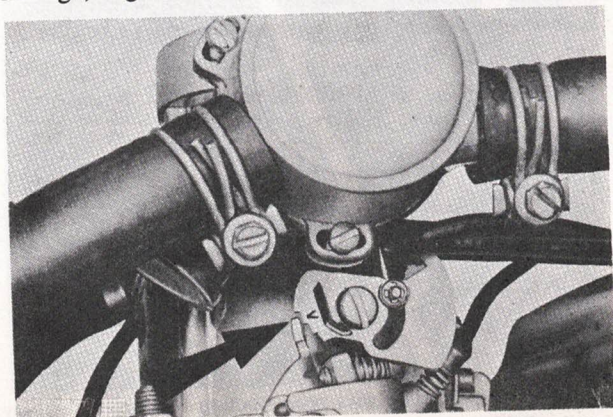

Fig. 26. Auto-choke mechanism set in fast idle position. Fast idle adjusting tag arrowed.

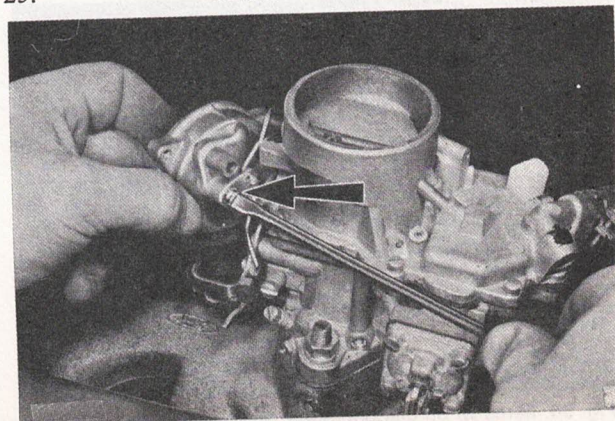

Fig. 28. Disconnecting choke linkage from auto-choke assembly.

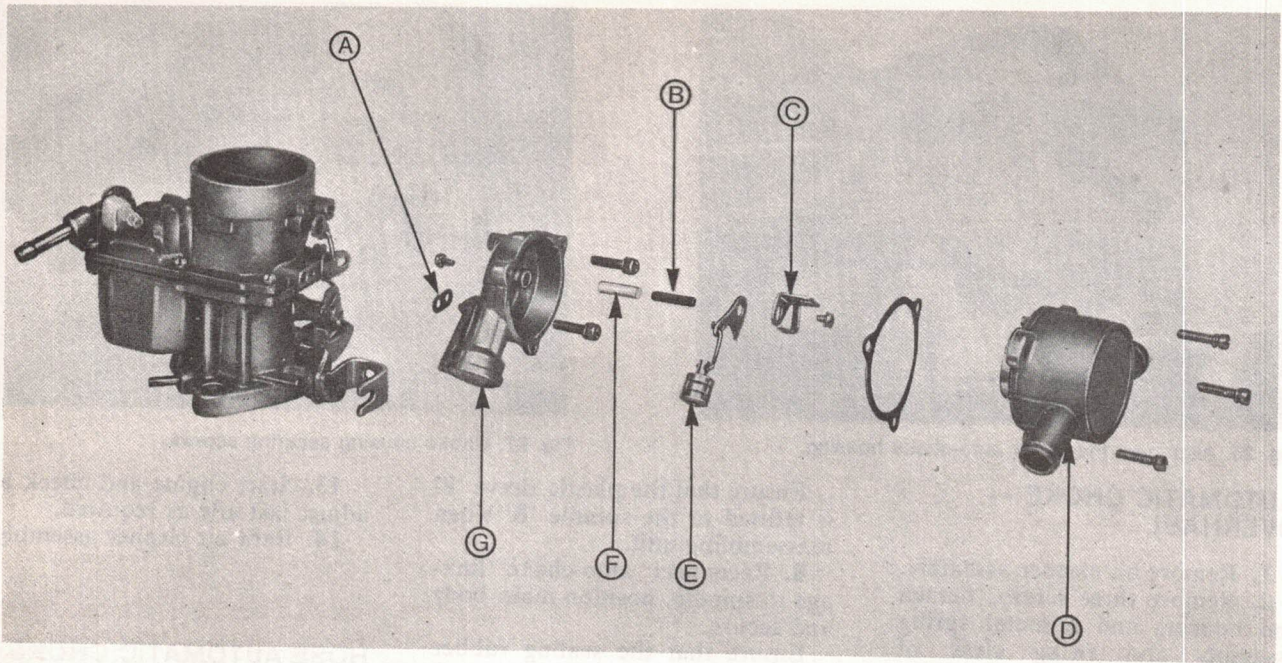

Fig. 29. Ford auto-choke assembly dismantled.

- A—Sealing gasket.
 B—Choke spindle.
 C—Operating link.
 D—Outer housing and bi-metal spring.
 E—Vacuum piston assembly.
 F—Spindle sleeve.
 G—Main choke housing.

CARBURETTOR — REMOVE AND INSTALL

To Remove

1. Remove air cleaner assembly.
2. Disconnect throttle link at carburettor.
3. Manual choke variants, disconnect choke inner and outer cable from carburettor, Fig. 30.
4. For automatic choke variants, disconnect both auto-choke hoses at carburettor.

Before disconnecting hoses ensure that cooling system is not pressurised (by removing radiator

cap and refitting) and that radiator cap is in position.

Position disconnected hoses facing upwards, this will ensure that only a negligible amount of coolant is lost.

5. Disconnect vacuum, vent and fuel feed pipes. If crimped type hose clamp is fitted it should be cut free and replaced with a screw type clamp, Fig. 31.

6. Remove two nuts and washers and detach carburettor assembly.

To Install

7. Clean gasket faces.
8. Transfer throttle clip to new carburettor.

9. Position carburettor with a new gasket and secure.

10. Manual choke variants, reconnect choke cable and adjust.

Adjust by pulling out cable from dash approximately 6 mm (0.25 in.) and reconnect cable to carburettor taking out all slack. Push home cable.

11. Automatic choke variants, reconnect both auto-choke hoses. Check and top up coolant level as required.

12. Reconnect throttle link.

13. Reconnect vacuum, vent and fuel feed pipes.

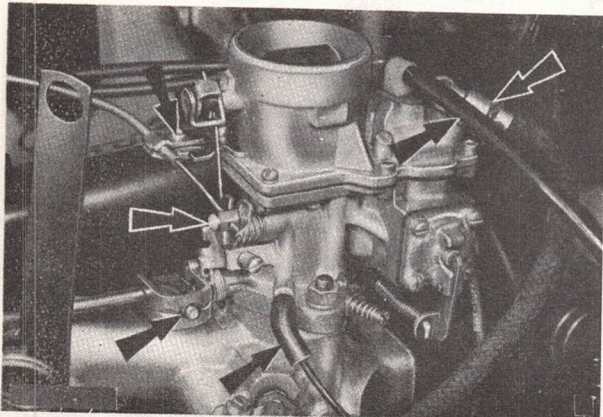

Fig. 30. Items to be disconnected when removing carburettor (manual choke variant shown).

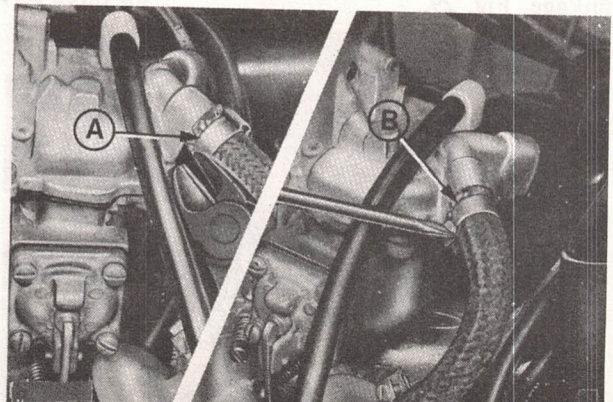

Fig. 31. Disconnecting and reconnecting carburettor supply pipe.
 A—Crimped type hose clamp.
 B—Screw type hose clamp.

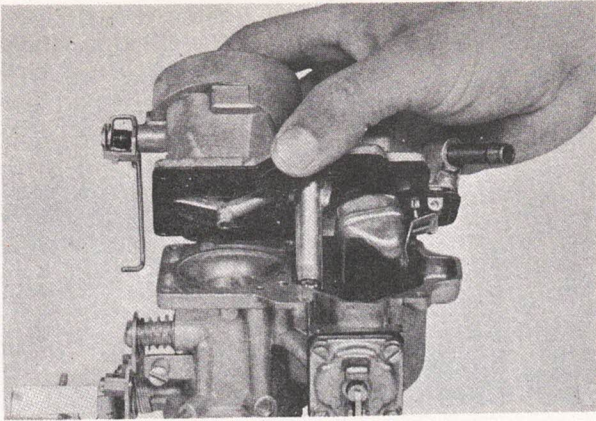

Fig. 32. Removal of carburettor upper body.

14. Refit air cleaner assembly.
15. Check and adjust engine idle speed and fuel mixture setting.

CARBURETTOR — CLEAN INSPECT AND ADJUST

1. Clean carburettor exterior.
2. Remove carburettor upper body assembly.
Remove six screws, disconnect choke link and detach upper body assembly, Fig. 32.
3. Remove accelerator ball valve and weight.
Remove by turning carburettor upside down and allowing weight and ball to fall out, Fig. 33.
4. Remove float, upper gasket, needle valve and valve housing and filter assembly.
Tap out float retaining pin and lift out float and needle valve.
Unscrew valve housing and detach filter from housing, Fig. 34.
5. Remove main jet.
6. Remove accelerator pump assembly.

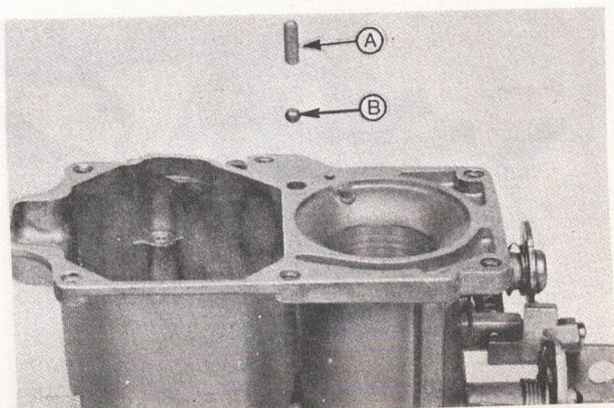

Fig. 33. A—Accelerator ball valve weight.
B—Accelerator ball valve.

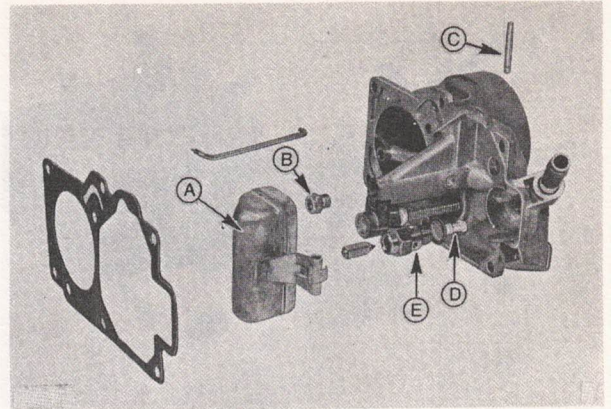

Fig. 34. Carburettor upper body dismantled.

- A—Float.
- B—Main jet.
- C—Float retaining pin.
- D—Intake filter.
- E—Valve housing.

Care should be taken to ensure the two return springs are not lost, Fig. 35.

7. Remove mixture screw.
8. Clean carburettor float chamber and jets.

Concentrate on components and jets shown, Fig. 36.

9. Inspect carburettor components.

The main items for inspecting are shown in Fig. 37.

The float checked for leaking, pump diaphragm and gasket inspected for splits and mixture screw, needle valve and throttle spindle checked for wear.

10. Refit mixture screw.
11. Reassemble accelerator pump assembly.

The sealing washer is fitted with steel side facing outwards and main return spring tapered inwards, Fig. 38.

12. Reassemble needle valve assembly and float.

Refit in reverse order as detailed in sub-operation 4. Ensure that the filter and sealing washer are fitted to valve housing before housing assembly is fitted to carburettor.

13. Check and adjust float level as required, to specification.

The float level is checked in two planes. Firstly with upper body held in vertical position and needle valve shut off, measure distance between upper body face and base of float, Fig. 39. The second check is made with upper body held in horizontal plane with float hanging fully open. Again check between upper body face and base of float, Fig. 40. The setting is adjusted by bending tags marked 'A' on the float.

NOTE: Upper body gasket must be removed during checks.

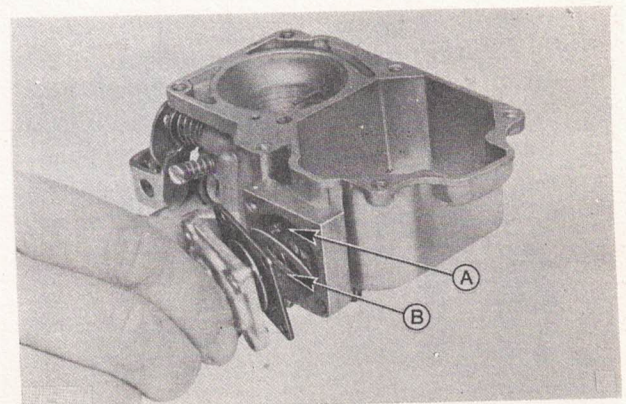

Fig. 35. Removal of accelerator pump assembly.
A—Check valve spring.
B—Diaphragm return spring.

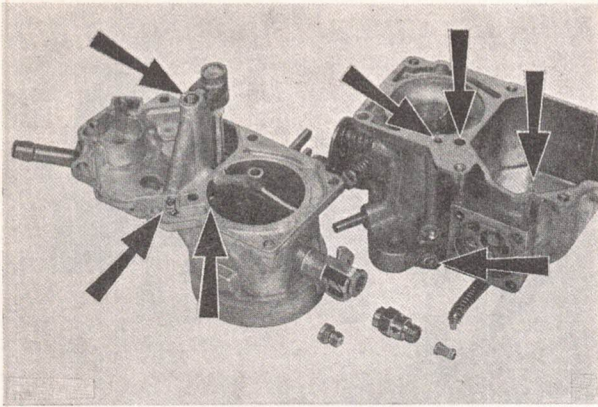

Fig. 36. Main items to be cleaned.

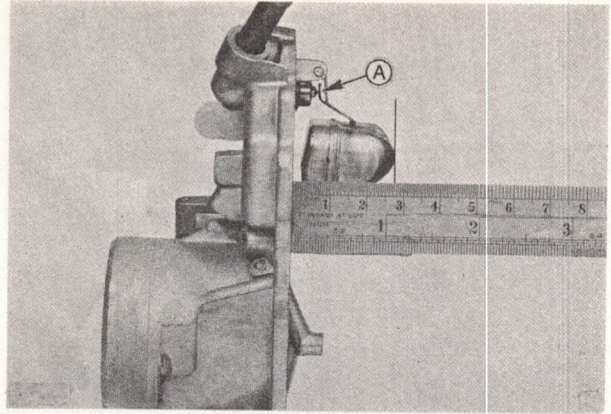

Fig. 39. Float level adjustment.
A—Adjusting tag.

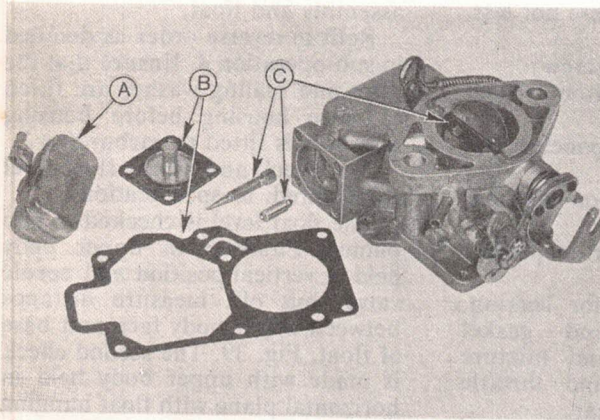

Fig. 37. Carburetor main body dismantled.
A—Checked for leaks.
B—Checked for splits or damage.
C—Checked for wear or damage.

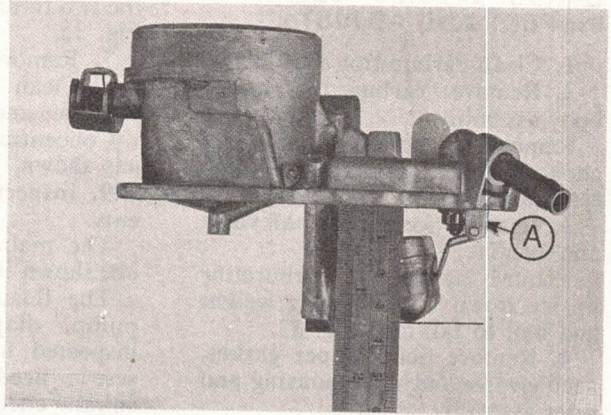

Fig. 40. Float travel adjustment.
A—Adjusting tag.

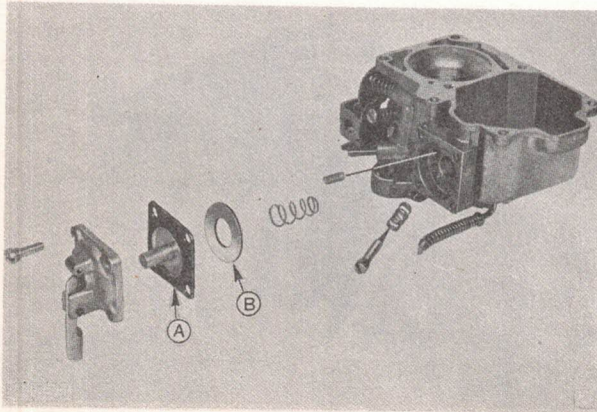

Fig. 38. Accelerator pump and mixture screw dismantled.
A—Accelerator pump diaphragm.
B—Sealing washer.

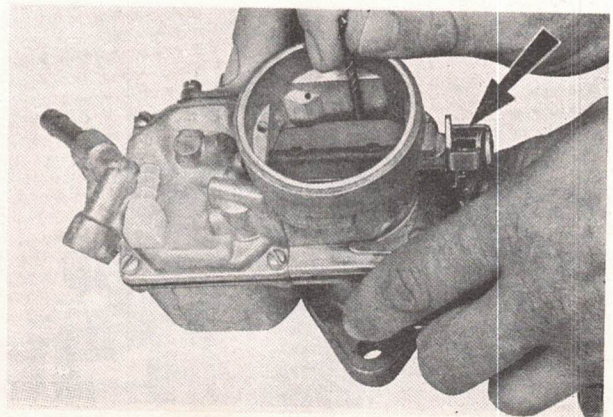

Fig. 41. Choke mechanism held in closed position to check choke plate pull down. Adjusting tag marked.

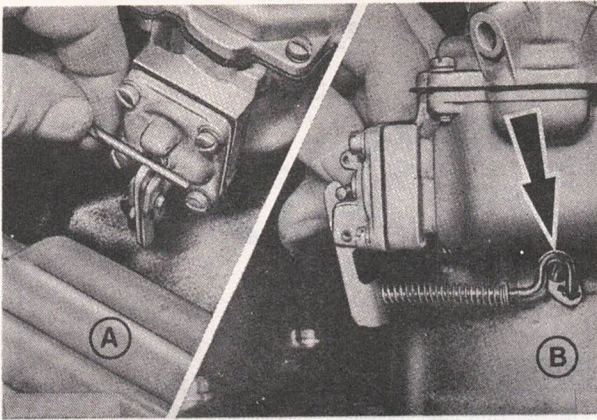

Fig. 42. Accelerator pump adjustment.
A—Checking pump stroke.
B—Adjustment position.

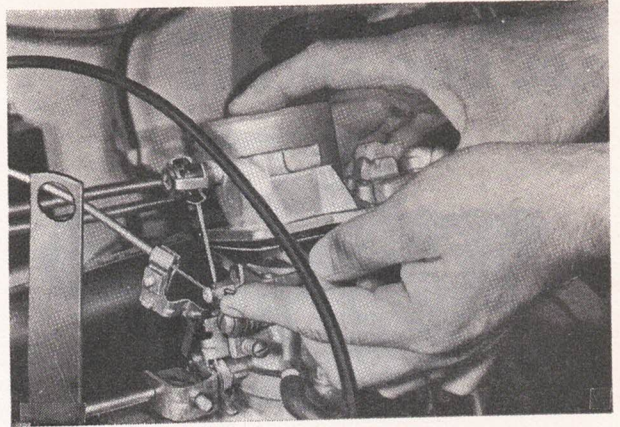

Fig. 44. Choke mechanism held fully closed when refitting upper body.

- 14. Refit main jet.
- 15. Refit accelerator ball valve and weight.
- 16. Position upper gasket, reconnect choke operating linkage and refit upper body.

For vehicles with manual choke ensure that cranked end of choke link is fitted at the bottom. Also when positioning upper body hold choke mechanism in fully closed position. This ensures that choke cam does not over-centre when upper body is installed.

- 17. Check and adjust choke pull down setting as required (Manual choke only), to specification.

Hold choke mechanism in fully closed position, by rotating cam on to its stop. Open choke plate against spring tension up to stop and measure clearance between choke plate and air horn with a gauge rod or drill. Adjustment is

carried out by bending tag marked, Fig. 41.

- 18. Check and adjust accelerator pump stroke as required, to spec.

Wind back idle speed adjusting screw clear of linkage.

With throttle in fully closed position manually push in the accelerator diaphragm to its stop and measure clearance between pump lever and diaphragm. Adjustment is carried out by opening or closing 'U' section on control link, Fig. 42.

NEEDLE VALVE — REPLACE

To Remove

- 1. Remove air cleaner assembly.
- 2. Clean carburettor exterior.
- 3. Disconnect fuel bowl vent tube.
- 4. Disconnect fuel supply pipe.
- 5. If a crimped type hose clamp

is fitted it should be cut free and replaced with a screw type clamp, Fig. 41.

- 6. Remove carburettor upper body assembly.

Remove six screws, disconnect choke link and detach upper body assembly.

- 7. Remove float and detach needle valve and valve housing.

Tap out float retaining pin and lift out float, and needle valve. Unscrew valve housing and detach filter from housing, Fig. 43.

- 8. Clean carburettor float chamber and jets.

Ensure accelerator ball valve and weight are not blown out.

- 9. Refit needle valve assembly and float.

Refit in reverse order detailed in sub-operation 7.

Ensure that filter and sealing washers are fitted to valve housing before housing is refitted to carburettor upper body.

- 10. Check and adjust float level setting.

- 11. Refit carburettor upper body.

Reconnect choke link, position upper body and secure. For vehicles with a manual choke when positioning upper body hold choke mechanism in fully closed position. This ensures that choke cam does not over-centre when upper body is installed, Fig. 44.

- 12. Reconnect fuel bowl vent tube.

- 13. Reconnect fuel supply pipe.

- 14. Refit air cleaner assembly.

- 15. Check and adjust engine idle speed and fuel mixture setting.

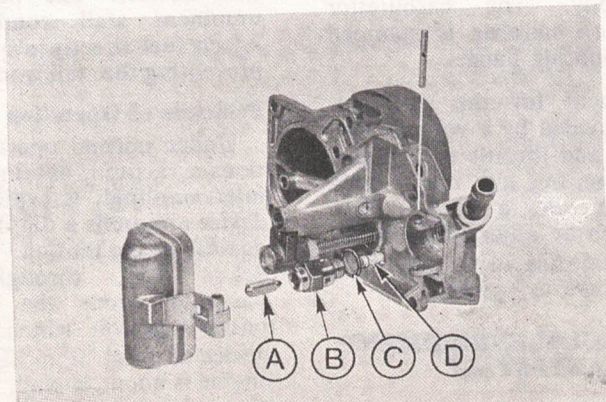

Fig. 43. Needle valve assembly dismantled.
A—Needle valve.
B—Valve housing.
C—Sealing washer.
D—Intake filter.

WEBER CARBURETTOR 2.0L OHC ENGINE

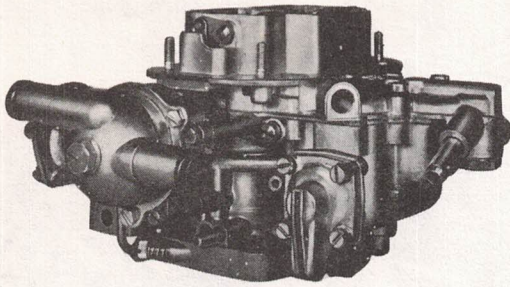

Fig. 45. Weber Carburettor and Automatic Choke.

Description

The 'Weber' dual barrel down-draught carburettor has the following systems, idling, main, full load enrichment, power valve and a diaphragm type accelerator pump system. Cold starting is by fully automatic choke. The float chamber is internally vented.

The carburettor consists of two castings forming the upper and lower bodies. The upper body incorporates the float chamber cover, float pivot brackets, fuel inlet connection tube, gauze filter, spring loaded needle valve, twin air intakes, choke plates and the section of the power valve controlled by vacuum. The lower body incorporates the float chamber, accelerator pump, low vacuum enrichment system, two throttle barrels and integral main venturis, throttle plates, spindles, levers, jets and the fuel power valve.

Throttle plate opening is sequential, the primary commencing to open first, followed by the secondary, both plates reaching full throttle simultaneously. The primary barrel, throttle plate and venturi is smaller than the secondary whilst the auxiliary venturi size is identical in both primary and secondary.

All the carburettor systems are in the lower body, the main, progression and idling systems operate in both barrels, the power valve system is in the primary barrel only and the full load enrichment system in the secondary barrel.

The accelerator pump discharges into the primary barrel.

A distributor vacuum connection is also provided and the choke linkage is mounted on the lower body. The carburettor identification number is stamped on the mounting flange.

Adjustment for the slow-running is provided by a volume control screw and throttle stop screw. Float setting, fast idle, choke plate pull down and a choke plate opening can be adjusted by bending the mounting arms, operating rods and tabs as specified.

LOW VACUUM ENRICHMENT SYSTEM [ANTI-STALL DEVICE]

To achieve low emission levels at idle it is necessary to calibrate the idle system with a leaner mixture setting. This leads to a tendency to

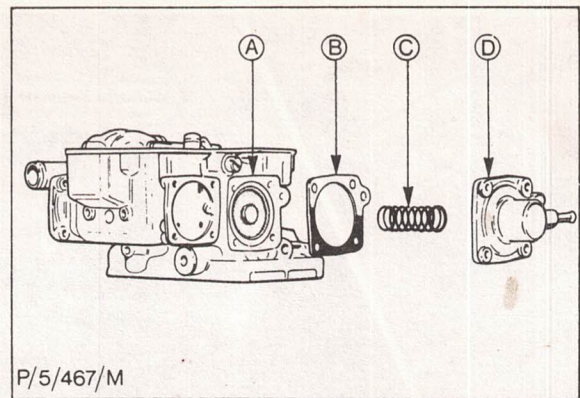

Fig. 46. Anti-stall device.

- A—Diaphragm.
- B—Gasket.
- C—Return spring
- D—Housing.

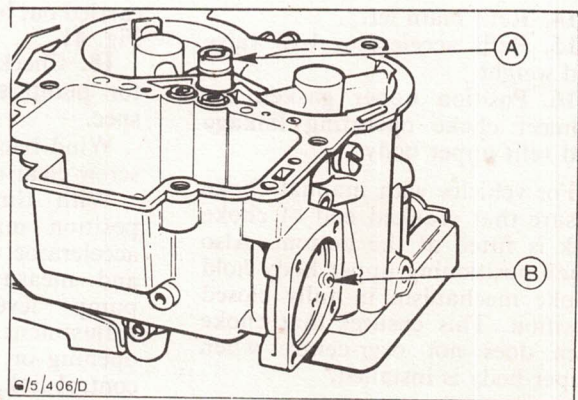

Fig. 47. Anti-stall device

- A—Discharge tube
- B—Fuel entry into unit

stall under certain operating conditions.

To overcome this problem the carburettors incorporate a low vacuum enrichment system (anti-stall device). The device senses imminent stall conditions and injects fuel directly into the venturi, preventing the stall from occurring.

Principle of Operation

Under normal operating conditions a vacuum, obtained from the inlet manifold, is available at the device and pulls a diaphragm back against spring tension. This in turn draws fuel, through internal passages, from the accelerator pump reservoir which enters the device at point 'B' in Fig. 47. If the engine is about to stall, the vacuum drops and the spring tension operates the diaphragm, pumping the reserve of fuel back into the internal passages and up to the discharge tubes ('A' in Fig. 47).

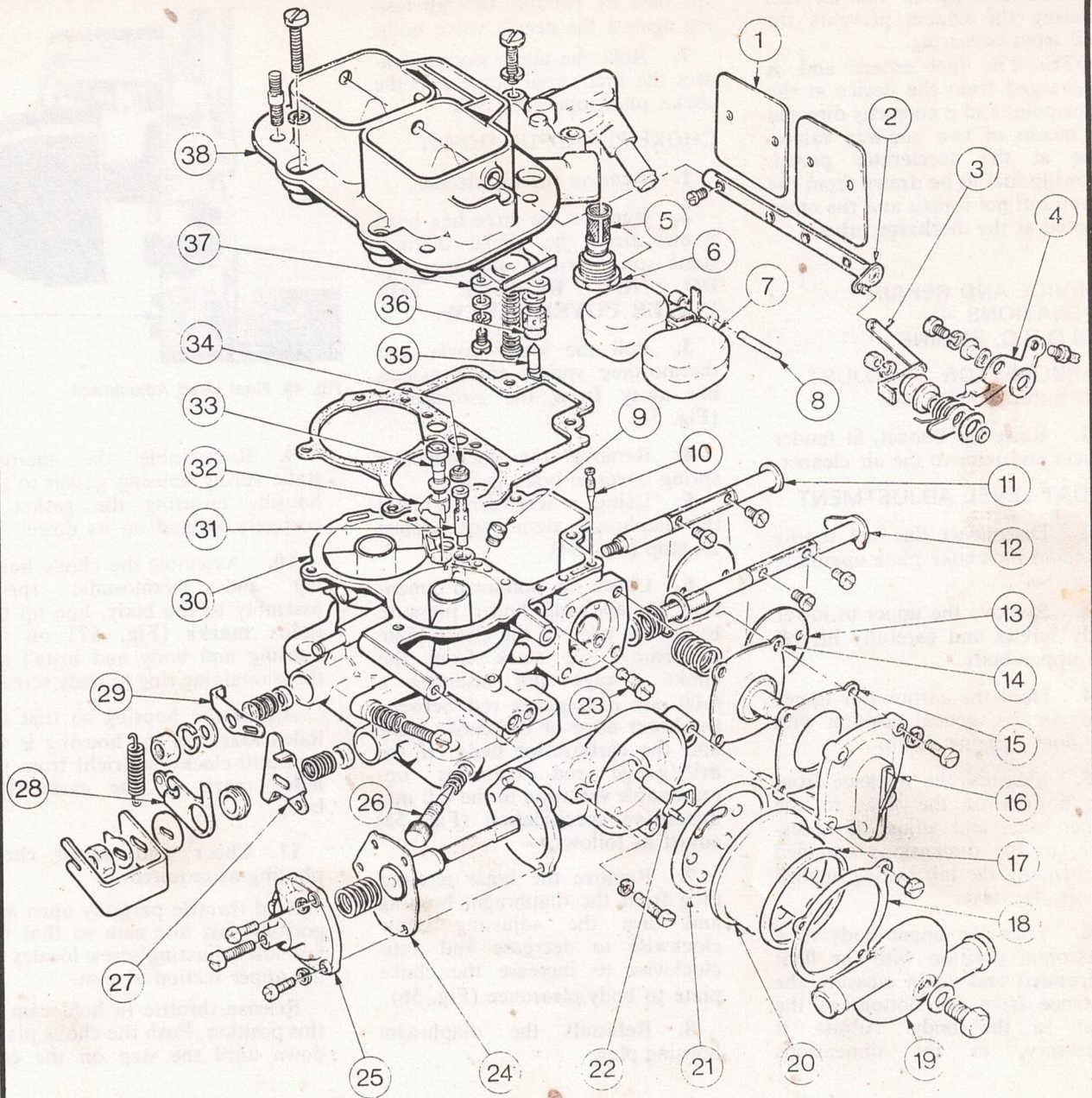

Fig. 47a – Weber Carburettor – Automatic Choke – 2000 Engine

- | | | |
|--------------------------------|--|---|
| 1. Choke plate | 15. Gasket | 28. Throttle control lever |
| 2. Choke plate shaft | 16. Accelerator pump cover | 29. Secondary throttle lever |
| 3. Choke plate lever assembly | 17. Gasket | 30. Lower body |
| 4. Fast idle lever | 18. Retaining ring | 31. Primary diffuser tube |
| 5. Filter | 19. Coolant housing | 32. Accelerator pump discharge jet |
| 6. Filter retaining screw | 20. Thermostatic spring housing | 33. Accelerator pump discharge ball check valve |
| 7. Float | 21. Insulating gasket | 34. Primary main air correction jet |
| 8. Float pivot pin | 22. Shaft and lever assy | 35. Needle valve |
| 9. Main jet (primary) | 23. Slow running jet and holder assembly | 36. Needle valve housing |
| 10. Accelerator blanking plug | 24. Diaphragm and shaft assembly | 37. Spring loaded diaphragm assembly |
| 11. Secondary throttle shaft | 25. Cover | 38. Upper body |
| 12. Primary throttle shaft | 26. Volume control screw | |
| 13. Throttle plate | 27. Throttle stop lever | |
| 14. Accelerator pump diaphragm | | |

Note: Anti-stall device not shown

This enrichment of the air/fuel entering the engine prevents the stall from occurring.

NOTE: The fuel enters and is discharged from the device at the same point and is correctly directed by means of two one-way valves. One at the accelerator pump, allowing fuel to be drawn from the pump but not return and the other located at the discharge tubes.

SERVICE AND REPAIR OPERATIONS — 2.0l O.H.C. ENGINE

CARBURETTOR — ADJUST (Carburettor installed)

1. Raise the bonnet, fit fender covers and remove the air cleaner.

FLOAT LEVEL ADJUSTMENT

2. Disconnect the fuel supply pipe and the choke plate operating rod.

3. Remove the upper to lower body screws and carefully lift off the upper body.

4. Hold the carburettor upper body in the vertical position with the float hanging down.

5. Measure the distance from the bottom of the float to the upper body and adjust, if necessary, to the dimensions specified by bending the tab resting against the needle valve.

6. Turn the upper body to a horizontal position with the float suspended and again measure the distance from the bottom of the float to the body. Adjust, if necessary, to the dimensions

specified by bending the tab resting against the needle valve body.

7. Refit the upper body. Connect the fuel supply pipe and the choke plate operating rod.

CHOKE PLATE PULLDOWN

1. Remove the air cleaner.

2. Remove the three hex head screws from the choke thermostatic spring cover retaining ring. **DO NOT REMOVE THE WATER COVER SCREW.**

3. Pull the water cover and thermostatic spring cover assembly away from the carburettor (Fig. 53).

4. Remove the thermostatic spring cover-to-body gasket.

5. Using a screwdriver, hold the diaphragm stem back against its stop (Fig. 54).

6. Check the pull-down dimension by applying finger pressure to the top edge of the choke plate to remove all slack from the choke linkage and inserting a 6.00 mm drill/gauge rod between the lower edge of the choke plate and the carburettor body. If the drill/gauge rod indicates unreasonable variation to the 6.0 mm dimension specification (Fig. 55) adjust as follows:—

7. Remove the brass screwed plug from the diaphragm housing and turn the adjusting screw clockwise to decrease and anti-clockwise to increase the choke plate to body clearance (Fig. 56).

8. Reinstall the diaphragm housing plug.

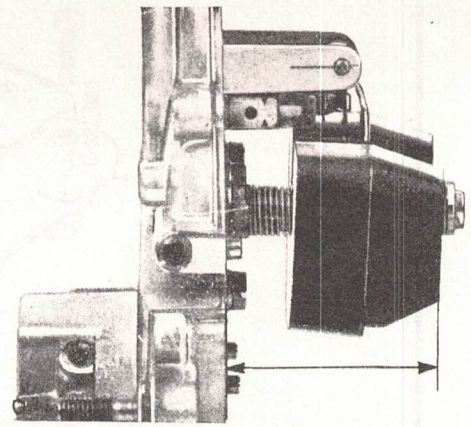

Fig. 49. Float Level Adjustment

9. Reassemble the thermostatic spring housing gasket to the housing ensuring the gasket is correctly located on its dowel.

10. Assemble the choke housing and thermostatic spring assembly to the body, line up the index marks (Fig. 57) on the housing and body and install the three retaining ring to body screws.

Adjust the housing so that the index mark on the housing is 4.0 mm anti-clockwise (rich) from the index mark on the carburettor body.

11. Check and adjust choke phasing as required.

Hold throttle partially open and position fast idle cam so that the fast idle adjusting screw locates on the upper section of cam.

Release throttle to hold cam in this position. Push the choke plates down until the step on the cam

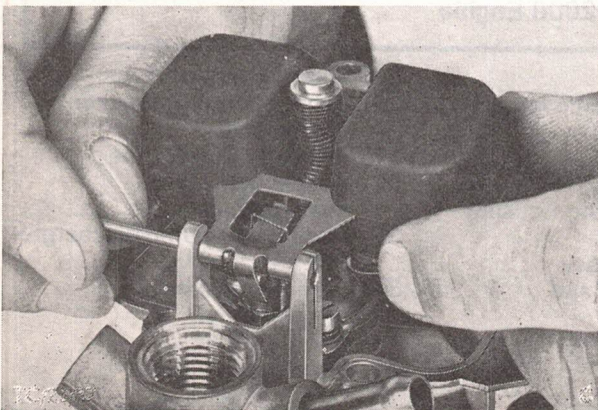

Fig. 48. Float Installation

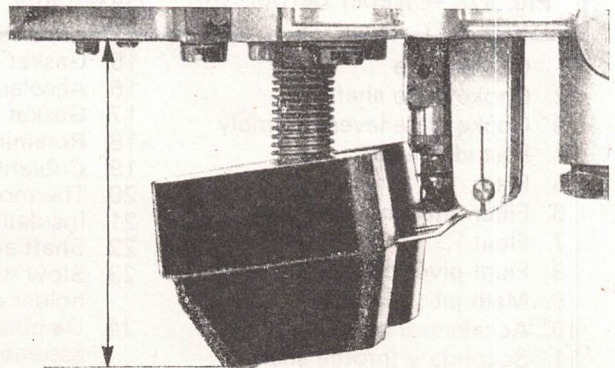

Fig. 50. Float Level Adjustment—Typical

jams against the fast idle adjusting screw. Fig. 51.

Release choke plates and measure clearance between choke plate and air horn on down draught side using a gauge rod or twist drill shank of 2.0 mm diameter.

12. Adjust choke phasing by bending tag, marked in Fig. 52.

13. Install the air cleaner.

IDLE MIXTURE AND SPEED ADJUSTMENTS

It is essential that whenever the idle speed is adjusted the CO level be checked and if necessary adjusted using a 'non-dispersive infra red' type of gas analyzer.

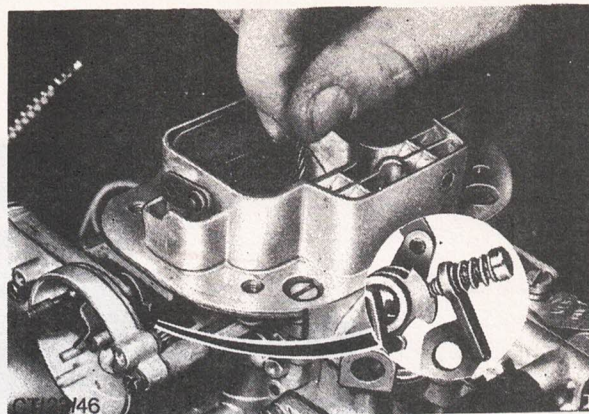

Fig. 51. Linkage Positioned to Check Choke Phasing

CURB IDLE SPEED AND CO LEVEL SETTING PROCEDURE

1. PRE-TEST PREPARATION

Before commencing an idle check, ensure that:

- (a) The engine temperature gauge is not reading above normal, and the engine has not been idling for more than 10 minutes.
- (b) Initial timing is set to specification.
- (c) The air cleaner is fitted correctly and the element is clean.
- (d) All vacuum hoses are correctly fitted.
- (e) Air conditioning (where applicable) is off.
- (f) A calibrated tachometer reading in increments of 20 rpm is available.
- (g) The CO meter is on, warmed up and calibrated.

2. ENGINE WARM UP

- (a) If the engine is not already at normal operating temperature start the engine and allow it to idle until the thermostat opens. Note: If the vehicle is fitted with a manual choke ensure that the choke is fully off in the shortest possible time.

- (b) Drive the vehicle for 3 kilometres at moderate speed. Ensure that the choke is fully off.

NOTE: THIS 3 KILOMETRE DRIVE IS ESSENTIAL TO STABILIZE ENGINE TEMPERATURE PRIOR TO CHECKING IDLE CO LEVEL.

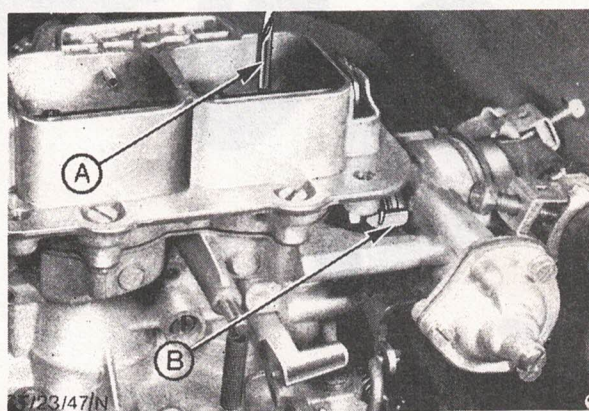

Fig. 52. Choke Phasing Adjustment
A—Twist Drill
B—Adjusting Tag

3. CURB IDLE SPEED AND CO CHECK AND ADJUSTMENT

- (a) After returning from the 3 kilometre drive **do not** switch off the engine. **THE ENGINE MUST IDLE FOR 5 MINUTES BEFORE CO READINGS ARE TAKEN.**

During this Period:—

- (i) Connect the tachometer.
- (ii) Connect the CO meter according to the manufacturer's instructions.
- (iii) Clamp the hose from the carburettor to the deceleration valve.

NOTE: This precludes possible erroneous readings caused by faulty deceleration valve operation. The deceleration valve cannot be correctly adjusted until idle speed and CO level have been set.

- (b) After the 5 minutes idle period has elapsed, increase the engine speed to 3000 rpm and maintain for 30 seconds. Allow the engine to return to idle for 10-20 seconds to enable the meter reading to stabilize and then check the idle speed and CO level in neutral gear.
- (c) If the idle speed or CO level is not to specification adjust the idle mixture screw and/or the idle speed screw to obtain the required settings.
- (d) Increase the engine speed to 3000 rpm and maintain for 30 seconds.
- (e) Allow the engine to return to idle for 10-20 seconds to enable the meter reading to stabilize.
- (f) Recheck idle speed and CO level to specification.

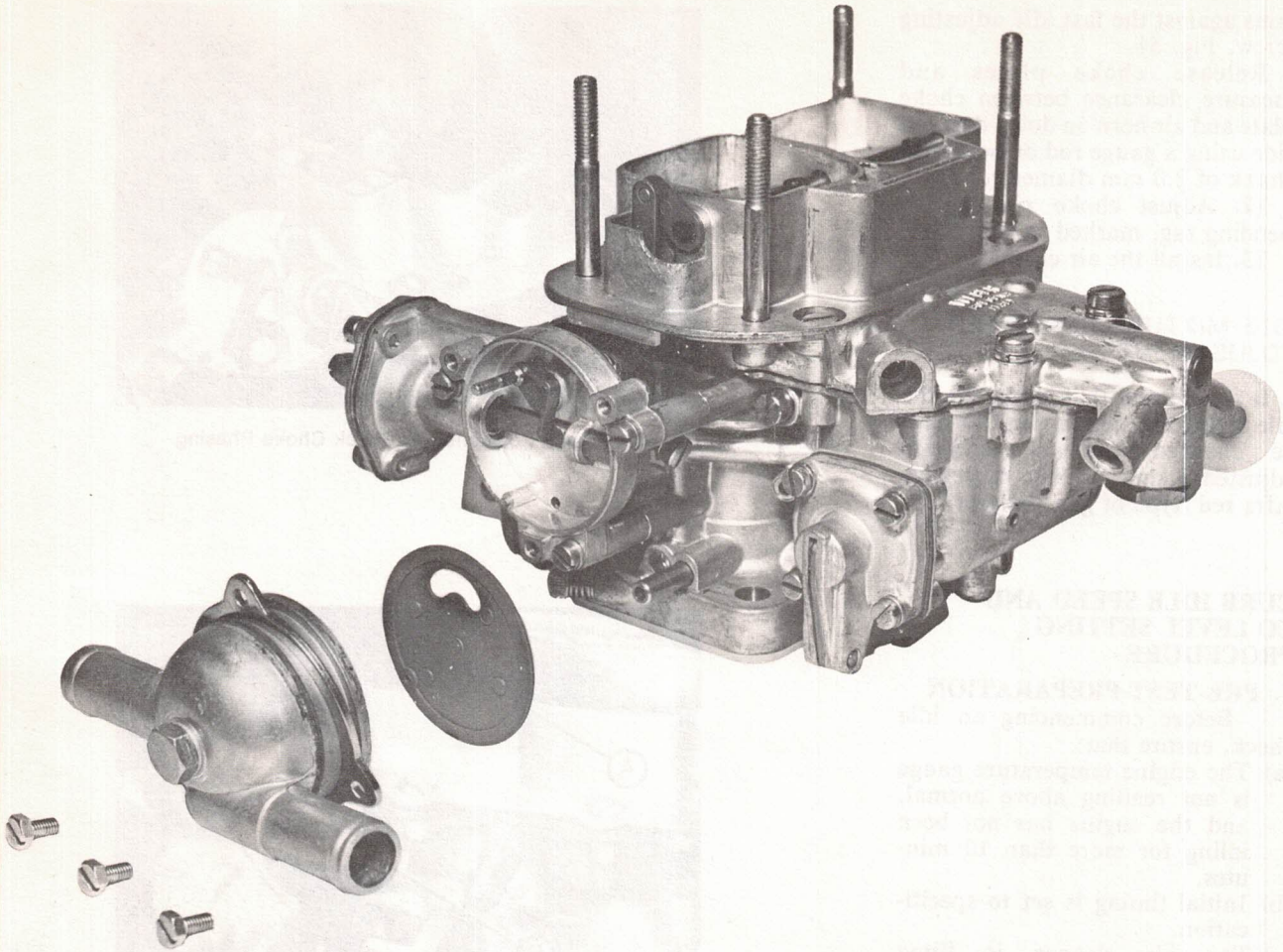

Fig. 53. Thermostatic Spring Cover Removal

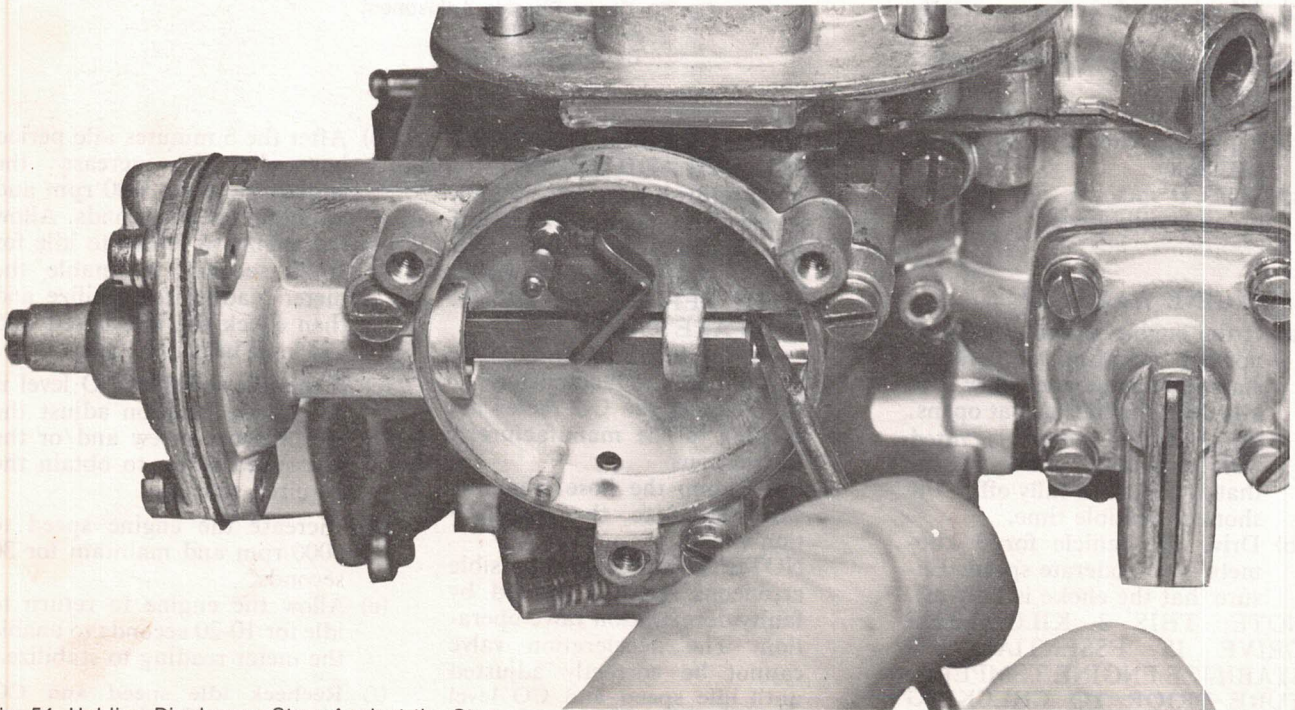

Fig. 54. Holding Diaphragm Stem Against the Stop

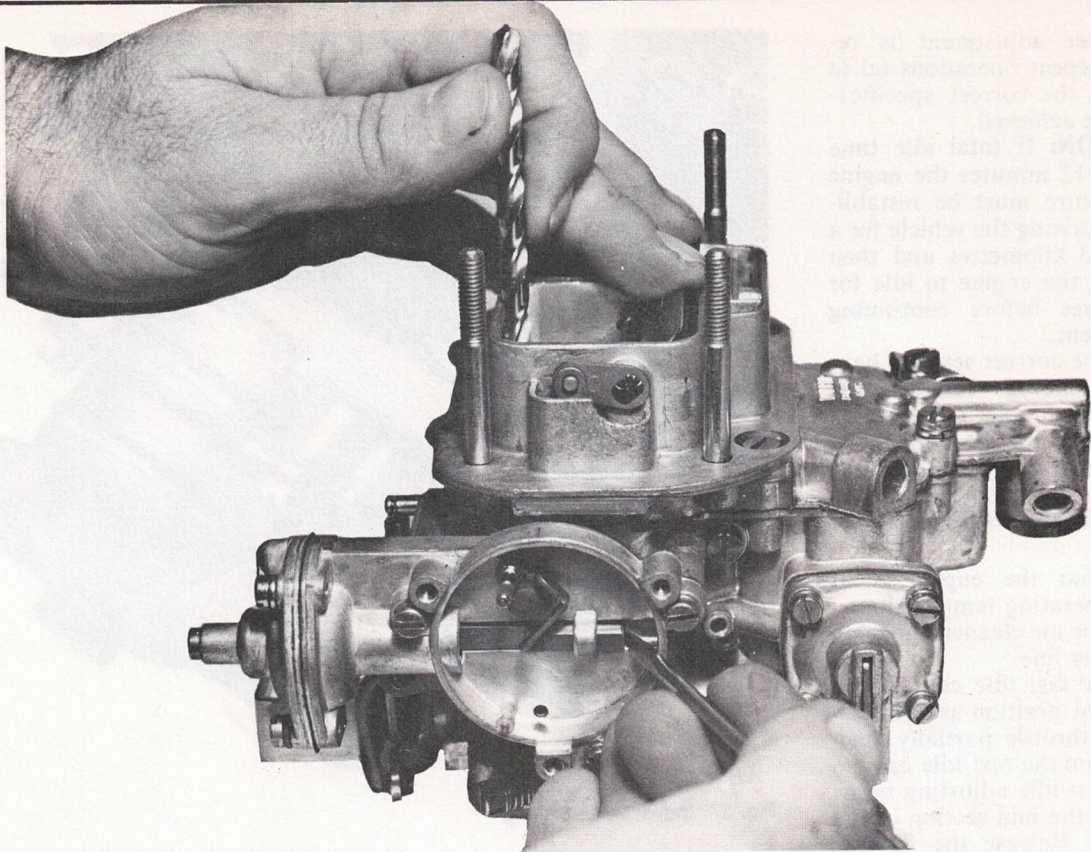

Fig. 55. Checking Choke Plate Pulldown Dimension

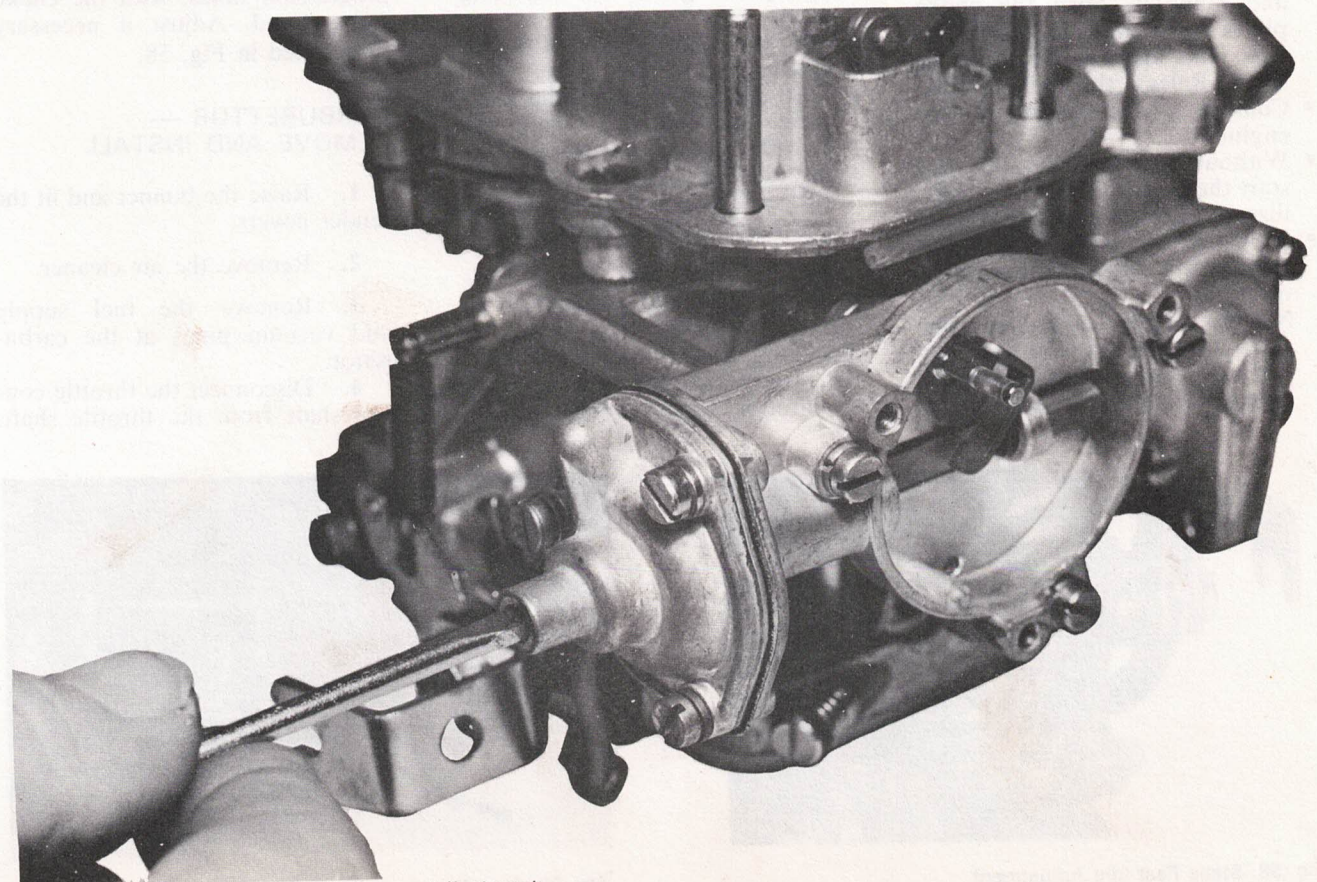

Fig. 56. Choke Plate to Body Clearance Adjustment

- (g) If further adjustment is required repeat operations (c) to (f) until the correct specifications are achieved.

CAUTION: If total idle time exceeds 12 minutes the engine temperature must be restabilized by driving the vehicle for a further 3 kilometres and then allowing the engine to idle for 5 minutes before continuing adjustment.

- (h) When the correct settings have been achieved remove the clamp from the deceleration valve hose and disconnect the tachometer and CO meter.

CARBURETTOR FAST IDLE SPEED

- Ensure that the engine is at normal operating temperature.
- Remove the air cleaner and plug the vacuum line.
- Locate the fast idle cam in the phase point position as follows: Hold the throttle partially open and position the fast idle cam so that the fast idle adjusting screw locates on the mid-section of the snail cam. Release the throttle to hold the cam in this position and manually push the choke plates down until the step on the cam jams against the adjusting screw. Release the choke plates.
- Connect a tachometer to the engine.
- Without touching the throttle, start the engine, allow it to stabilize and note the fast idle speed.
- Adjust as necessary by screwing the fast idle adjustment screw in or out.

NOTE: After adjusting the screw, ensure that the cam has not moved by pushing down the choke plates until the step on the

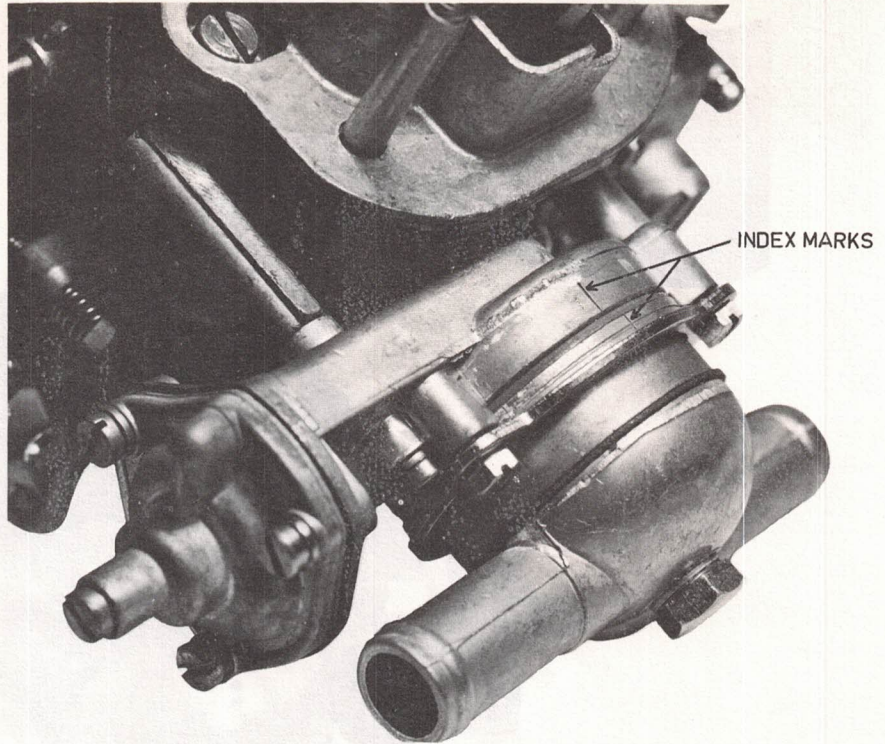

Fig. 57. Index Mark Setting

cam jams against the adjusting screw.

- Stop the engine and re-fit the air cleaner and vacuum tube.
- Start the engine and re-check the curb idle speed. Open the throttle slightly to release the fast idle cam before checking the curb idle speed. Stop the engine and remove the tachometer.

NOTE: The fast idle adjustment can be made statically, with the carburettor removed, by measuring the clearance between the primary throttle plate and the carburettor body adjacent to the

progression holes, with the choke fully closed. Adjust if necessary as detailed in Fig. 58.

CARBURETTOR — REMOVE AND INSTALL

1. Raise the bonnet and fit the fender covers.
2. Remove the air cleaner.
3. Remove the fuel supply and vacuum pipes at the carburettor.
4. Disconnect the throttle control shaft from the throttle shaft.

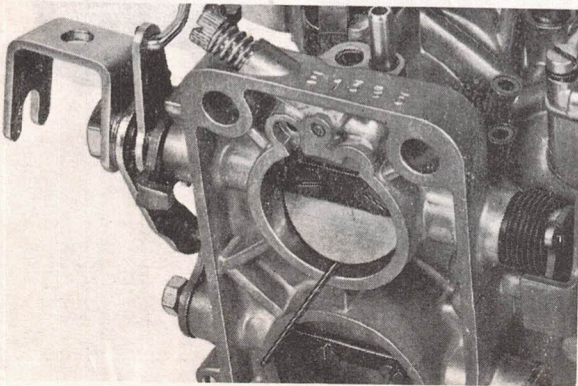

Fig. 58. Static Fast Idle Adjustment

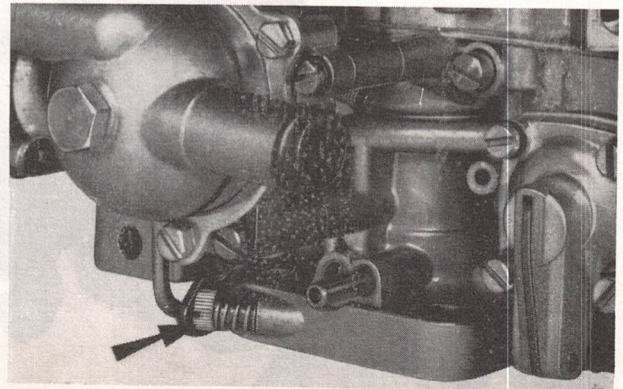

Fig. 59. Slow Running Idle Adjusting Screw

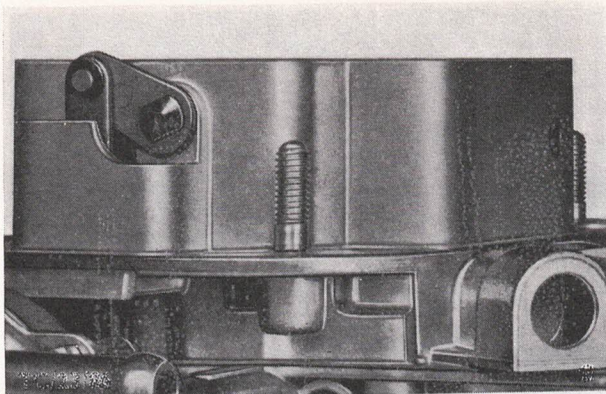

Fig. 60. Choke Rod Removal

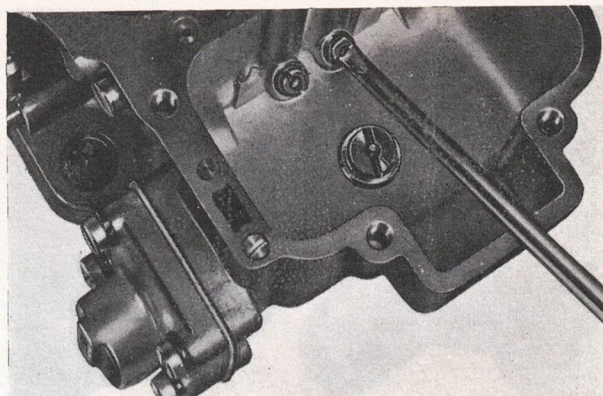

Fig. 62. Main Jet Removal

5. Partially drain the cooling system and disconnect the automatic choke hoses.

6. Remove the retaining nuts and spring washers then lift off the carburettor.

To Install

7. Ensure mating faces of carburettor and intake manifold are clean.

8. Locate a new gasket on the manifold, position the carburettor and secure with spring washers and nuts.

9. Reconnect the fuel supply and vacuum pipes.

10. Refit throttle control shaft to the throttle lever.

11. Refit the hoses to the automatic choke then refill the radiator. Check for leaks.

12. Install the air cleaner.

13. Re-adjust the slow running.

CARBURETTOR — OVERHAUL

To Dismantle

1. Remove the fuel filter retainer from the upper body and withdraw the filter.

2. Disconnect the choke plate operating rod at its upper end.

3. Remove the upper body retaining screws and lift off the body. Remove the gasket.

4. Withdraw the float pivot pin and remove the float and needle valve. Unscrew the needle valve housing.

5. Remove the screws to release the spring loaded diaphragm assembly.

6. Remove the accelerator pump cover, diaphragm and spring by unscrewing the four retaining screws. If necessary, drive out the pivot pin from the plain end with a suitable punch and remove the accelerator pump lever.

7. Remove the anti stall device cover screws, cover, spring, diaphragm and gasket.

8. Remove the choke plate operating rod dust seal from the air cleaner flange.

9. File the ends of the choke plate retaining screws. Remove the screws and withdraw the plates. Clean the burrs from the threaded holes then withdraw the shaft.

10. Unscrew the primary and secondary main jets from the base of the float chamber. Do not remove the power valve from the centre of the float chamber base.

11. Unscrew and remove the accelerator pump discharge valve from the top of the carburettor body together with the discharge jet.

12. Remove the air correction jets from the top of the carburettor body, invert the latter and slide out the emulsion tubes.

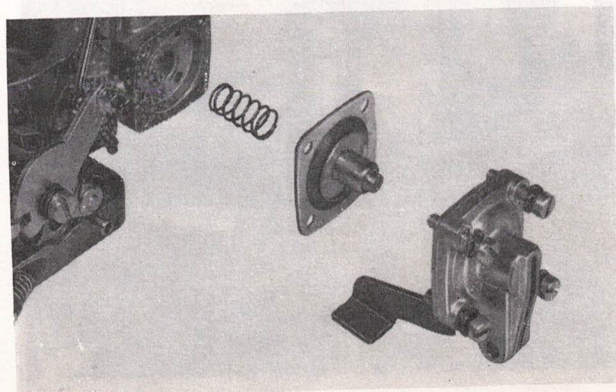

Fig. 61. Accelerator Pump Removal

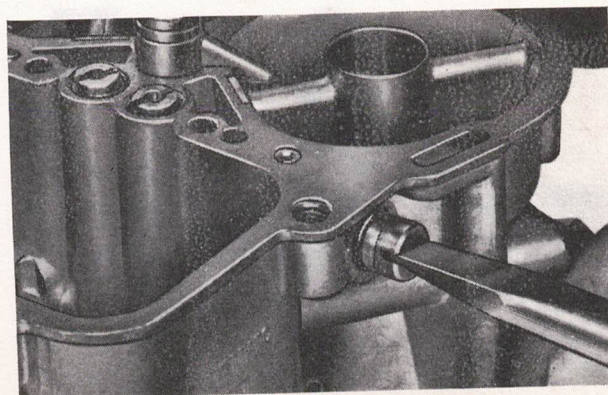

Fig. 63. Idling Jet Holder Removal

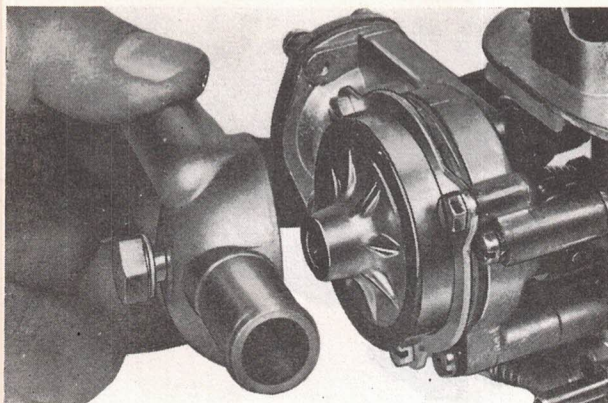

Fig. 64. Automatic Choke Removal

13. Unscrew the two idling jet holders, one from either side of the carburettor body. Remove the idling jets.

14. Remove the volume control screw and spring from the base of the body.

15. Unhook the secondary throttle return spring from the secondary throttle control lever.

16. Remove the pin from the fast idle rod at the primary throttle lever. Straighten the lock tab and unscrew the nut on the primary throttle shaft and remove the throttle control lever, spacer, secondary throttle control lever, bush, slow running stop lever and spring from the spindle.

17. Unscrew the nut and remove the washer and lever from the secondary throttle spindle.

18. File the ends of the throttle plate retaining screws. Unscrew the throttle plate screws, remove the plates, remove any burrs from the threaded holes and withdraw the shaft.

AUTOMATIC CHOKE

19. Remove the centre screw to release the choke water housing and gasket.

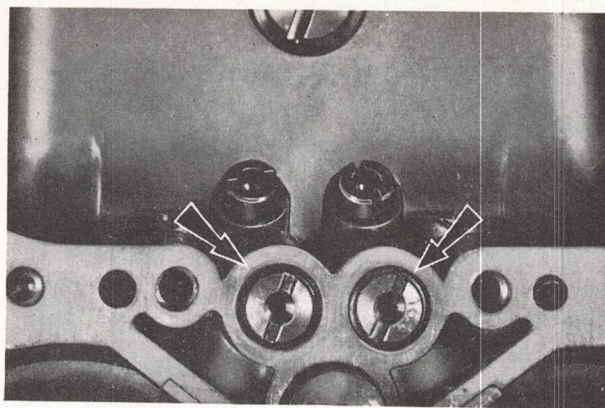

Fig. 67. Emulsion Tube Location

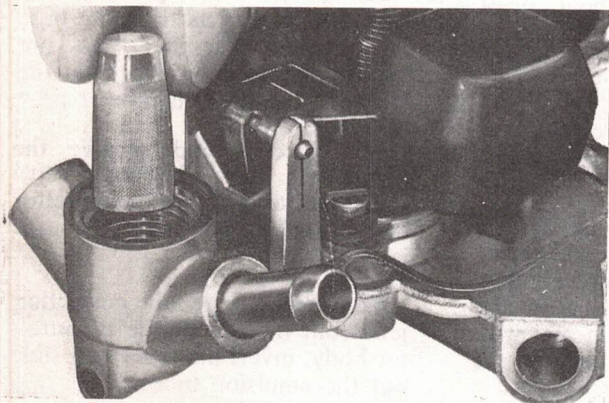

Fig. 65. Filter Installation

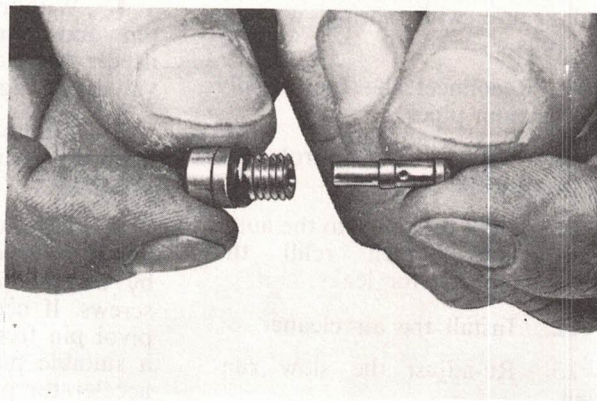

Fig. 68. Idling Jet Installation

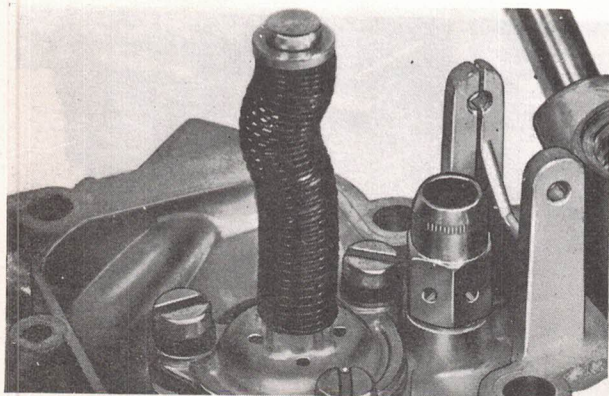

Fig. 66. Diaphragm Installation

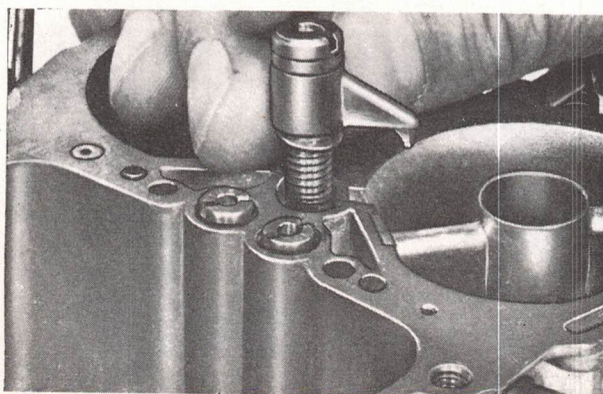

Fig. 69. Discharge Valve Installation

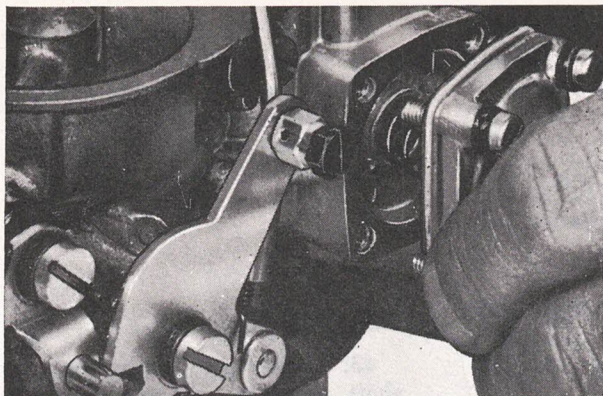

Fig. 70. Accelerator Pump Installation

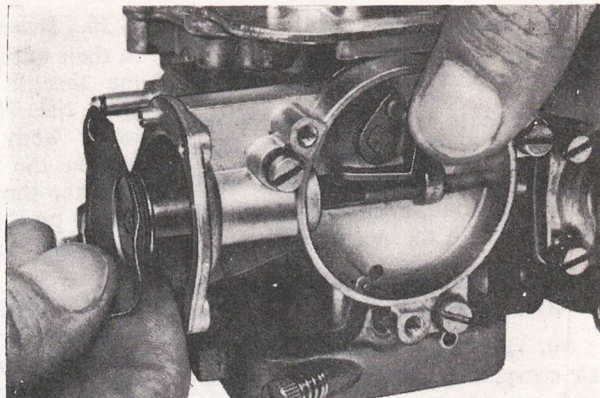

Fig. 73. Automatic Choke Diaphragm Installation

20. Unscrew the clamping ring screws, remove the ring, thermostatic spring housing and insulating gasket.

21. Remove the screws to release the diaphragm cover and spring.

22. Withdraw the diaphragm and spindle assembly.

To Reassemble

23. Insert the filter in the upper body and screw in retaining plug.

24. Insert the choke spindle in its bore, locate the choke plates in the shaft with the minus sign uppermost. Secure with new

screws and peen over the threaded ends to lock.

25. Fit the dust seal to the air cleaner flange, pass the choke rod through the seal and connect it to the choke spindle lever.

26. Locate the spring-loaded diaphragm assembly in the upper body and secure with screws.

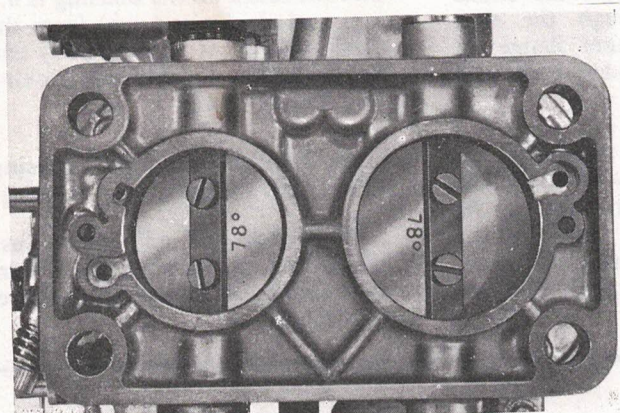

Fig. 71. Throttle Plate Location

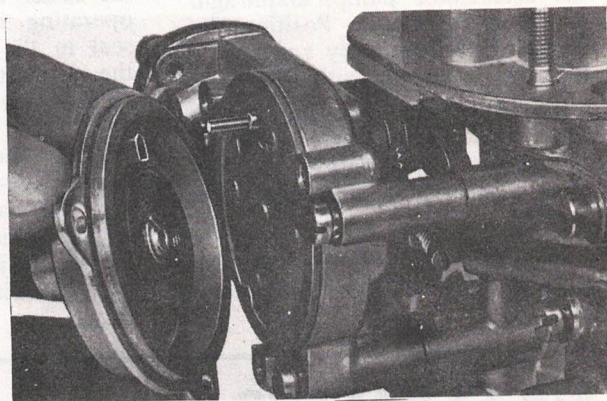

Fig. 74. Thermostatic Spring Housing Installation

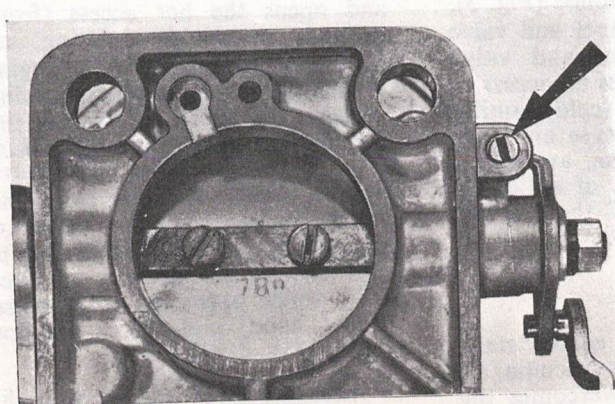

Fig. 72. Secondary Throttle Plate Adjustment Screw

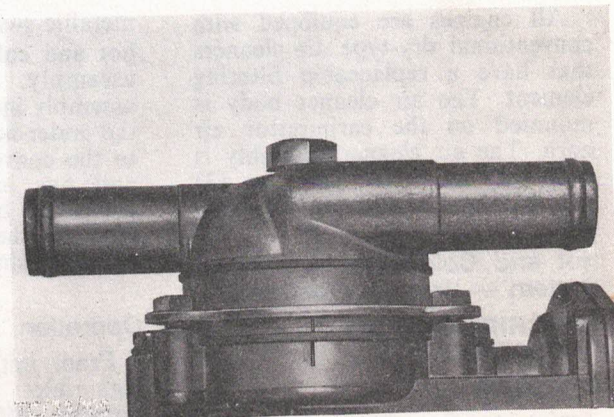

Fig. 75. Locating Mark Alignment Automatic Choke

27. Screw the needle valve housing, fitted with new gasket, into the float chamber cover.

28. Locate the needle valve in the housing and secure the float to the pivot bracket with the pivot pin simultaneously engaging the float with the needle valve.

29. Check the float settings as detailed previously.

30. Fit the emulsion tubes, air correction jets and the primary and secondary main jets in their respective locations in the lower body.

31. Locate the idling jets within their holders then fit the assemblies fitted with new 'O' ring, one to either side of the lower body.

32. Locate the discharge valve, with a new washer positioned on the top and lower face, on the discharge jet and secure the assembly to the lower body.

33. Locate a new gasket and the accelerator pump, diaphragm on the pump cover. Position the spring within the body and secure the cover assembly with screws.

34. Position the anti-stall diaphragm on the body, position the spring, a new gasket and the cover and secure with the four screws.

35. Fit the volume control screw and spring to the lower body base.

36. Insert the throttle shafts in their appropriate bores, position the throttle plates in the shafts with the 78° mark towards the lower body base. Fit and fully tighten the new retaining screws with the throttle plates in the fully closed position peen threaded ends of screws to lock.

37. Position the spring, lever and washer on the secondary throttle spindle and secure with nut and spring washer.

38. Locate the spring, slow running stop lever, washer, fast idle lever, waved washer, bush, secondary throttle control lever, spacer, throttle control lever on the primary throttle shaft and secure with plain washer and nut.

39. Engage the secondary throttle return spring in the throttle control lever.

40. Position a new gasket on the lower body, locate the choke operating rod through the dust seal in the air cleaner flange, fit the upper to the lower body and secure with screws.

41. Check the clearance between the secondary throttle plate and the carburettor body at its widest point with the throttle closed. Adjust the stop as necessary to obtain the specified clearance.

42. Refit the accelerator pump lever if previously removed and secure with pin entering the pin plain and foremost. Drive in pin until the serrated end is flush with the casing.

AUTOMATIC CHOKE

43. Locate the diaphragm and shaft assembly within the inner choke housing. Position the spring and cover on the diaphragm, and secure with screws.

44. Position the insulating gasket on the inner housing followed by the thermostatic spring housing. Ensure that the spring loop engages the crank pin and that the gasket and housing engage the dowel pin.

45. Align the locating marks so that the mark on the housing is 4.0 mm anti-clockwise (rich) from the mark on the carburettor body and retain the housing with the locking ring and screws.

46. Position the water housing gasket and fit the water housing.

47. Check and adjust the fast idle setting, choke plate pull-down and choke plate opening where applicable.

AIR CLEANERS

GENERAL

All engines are equipped with conventional dry-type air cleaners that have a replaceable filtering element. The air cleaner body is mounted on the carburettor air horn. The air cleaner assembly is retained on the engine by (3) brackets on 1.6l and (4) screws on 2.0l.

Hot and Cold Type Air Intake System — Vacuum Operated.

DESCRIPTION AND OPERATION

Description

The air cleaners feature inlet manifold vacuum operated, bi-

metallic switch controlled (Fig. 3), hot and cold type duct and valve assembly. The duct and valve assembly incorporates an access to the under-hood area (cold), similar to the conventional type air filter, and has in addition an access connected by means of a flexible pipe to the top of the exhaust manifold shroud (hot).

Operation

From initial cold engine start, high inlet manifold vacuum/air pressure difference overcomes the duct butterfly spring tension and closes the duct cold access opening

and opens the hot access (from exhaust manifold) opening, as shown in Fig. 4. (A). As the engine warms, the resultant hot air flowing through the air cleaner causes the thermal-operated bi-metal switch (Fig. 3) to unseat the bleed valve which 'bleeds' vacuum from the duct valve. The reduced vacuum/air pressure difference is overcome by the spring in the duct valve which opens the cold access (under hood) and closes the hot access (Fig. 4. (B)).

Incoming air is filtered through the filtering element as with the conventional dry type air cleaner.

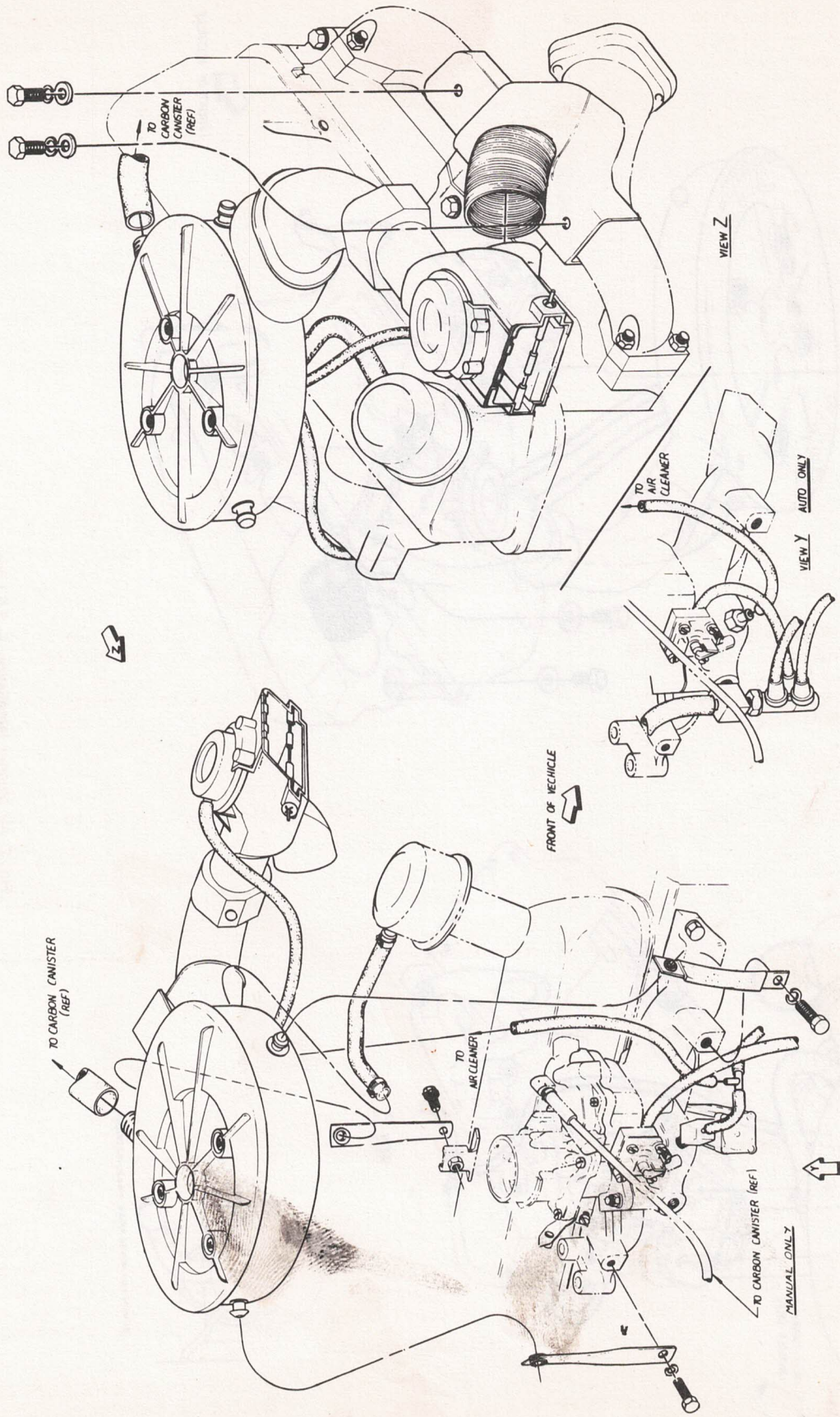

Fig. 1. Air Cleaner Installation — 1.6 Litre

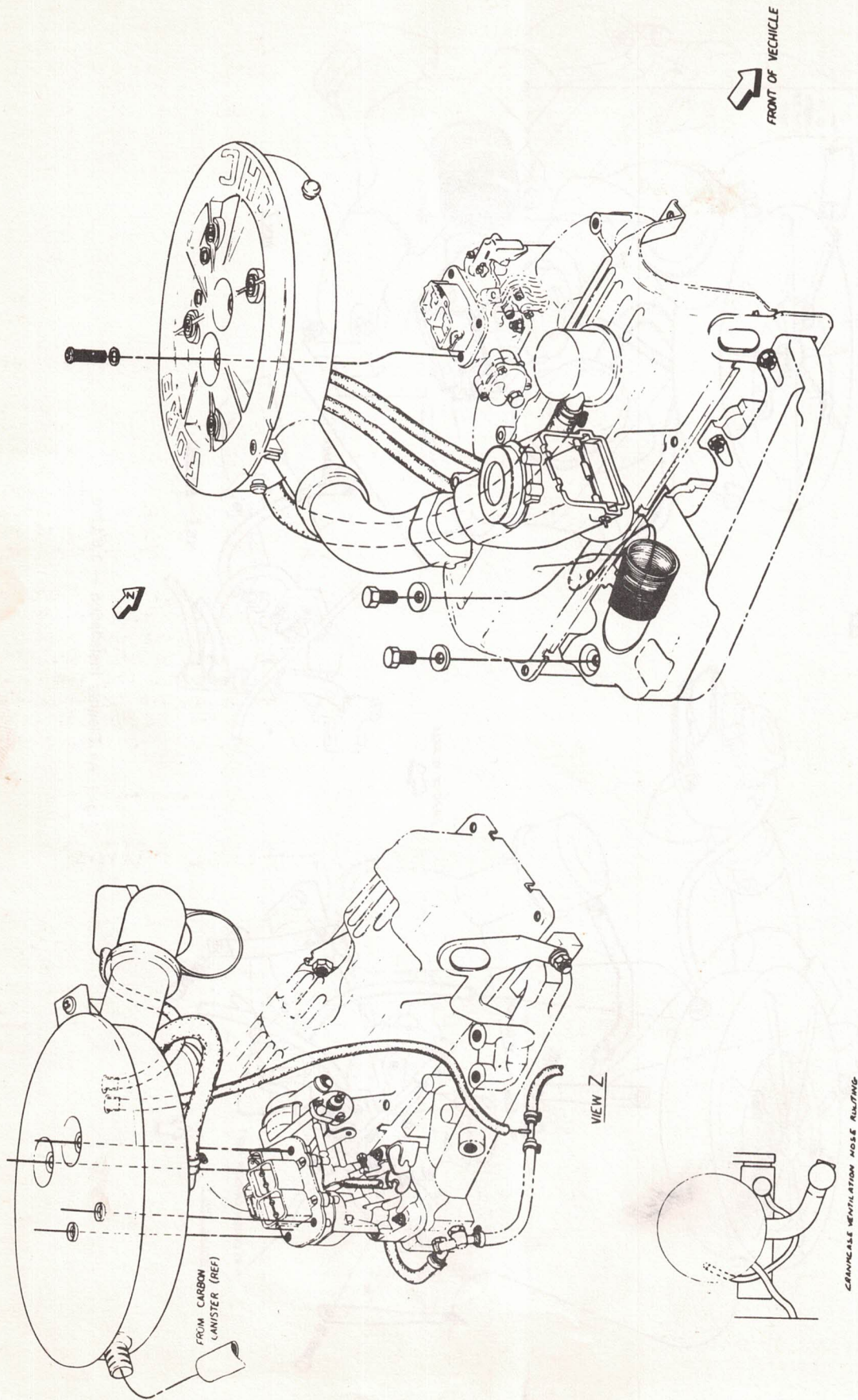

Fig. 2. Air cleaner installation — 2.0 Litre

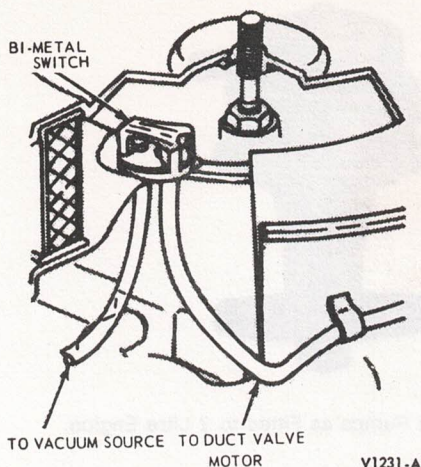

Fig. 3. Bi-Metal Switch—typical

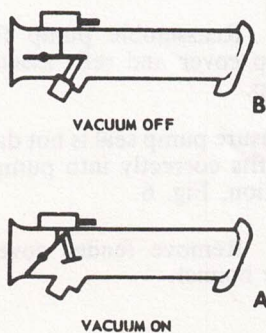

Fig. 4. Duct and Valve Assembly

DUCT AND VALVE ASSEMBLY TEST COLD CHECK:

- Check to see that the duct valve door is in the open (heat off, no vacuum) position when the engine is not running. If the duct valve door is closed, check for binding and sticking. Repair or replace as necessary.
- With the engine and inlet system cold and the engine at idling speed, the duct valve door should be closed or in the full heat-on position. If the duct valve door is not closed, turn off the engine. Cool the temperature sensor artificially using an air line, dry ice, etc.
- Restart the engine. The duct valve door should now be closed with the engine idling. If the valve door is still open check the related vacuum system.

HOT CHECK:

- With the engine at normal operating temperature and correct idling speed, the duct

valve door should be open to cold air (under hood ambient). If the duct valve door does not open as the engine reaches normal operating temperature replace the temperature sensor switch.

VACUUM MOTOR TEST:

- With the engine idling in a cold condition, i.e. duct valve door closed (heat on), disconnect the vacuum at the vacuum motor. The valve door should 'snap' open to the cold air position indicating correct operation of the vacuum motor.

The bi-metal switch can be functionally checked by subjecting the switch to heated air or removing and immersing the switch in water heated to 21-26 degrees C (69-77 degrees F). Only slight movement of the bi-metal is necessary to unseat the bleed valve.

HOT AND COLD TYPE VACUUM OPERATED AIR CLEANER

Removal and Installation

Refer to Group 19 for the air cleaner assembly recommended maintenance interval.

Clean or Replace Element

NOTE: To prevent dirt from entering the carburettor, the filter element must never be removed when the air cleaner body is mounted on the carburettor.

- Disconnect the intake duct vacuum hose from the manifold and the evaporative emission canister purge tube from the air cleaner. Disconnect the crankcase emission hose.
- On 1.6l, carefully prise out three mounting stays clear of the air cleaner, with a screwdriver. On 2.0l, remove (4) screws attaching air cleaner to carburettor. Lift the assembly from the carburettor.
- Separate the cover from the body of the cleaner and lift out the element.
- Clean the air cleaner body with a solvent and compressed air, wipe dry.
- Inspect the air cleaner body and cover for distortion, or damage at the carburettor mating surface. Renew the cover or body if they are damaged beyond repair.

- Hold the element in a vertical position and tap it lightly against a smooth vertical surface to shake the dust and dirt out. Do not deform the element or damage the sealing surfaces by tapping too hard. Rotate the element after each tap until the entire outer surface has been cleaned.
- Inspect the element by holding it in front of a light. If the element is split or cracked, renew the element.
- Place the element in the air cleaner body and position the cover on the body. Secure cover to air cleaner body with screws previously removed.
- Mount the air cleaner assembly on the carburettor and secure with the (4) attaching screws on 2.0 litre and (3) brackets on 1.6 litre. On 1.6 litre, ensure mounting rubbers are lubricated and correctly located in brackets prior to clipping to air cleaner body.
- Check that the hot air intake tube is correctly located on the exhaust manifold shroud and connect the intake duct vacuum hose and the evaporative emission canister purge tube.
- Connect the crankcase emission hose to the air cleaner body.

FUEL PUMP

The mechanical type fuel pump is mounted on the cylinder block and incorporates a nylon mesh filter located in the pump top housing. With the exception of the pump top and filter assembly the pump is a sealed unit and cannot be overhauled.

2.0 LITRE

It is a pushrod type single action pump driven by an auxiliary shaft on the left-hand side of the engine.

One of two alternative pumps is fitted to the 2.0l engine. Figs. 1 and 2.

1.6 LITRE

This pump is a lever type fitted to the right side of the cylinder block. It is driven by an eccentric on the camshaft. Fig. 3.

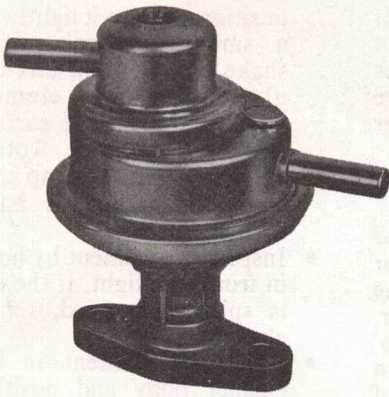

Fig. 1. Alternative Pumps as Fitted to 2 Litre Engine.

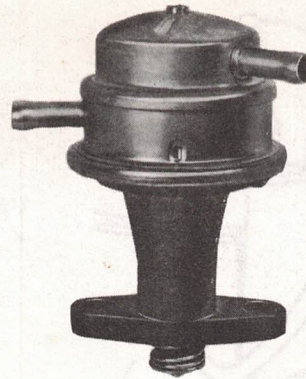

Fig. 2. Alternative Pumps as Fitted to 2 Litre Engine.

FUEL PUMP — DELIVERY PRESSURE — CHECK

1. Open bonnet and fit fender covers.
2. Remove air cleaner assembly.
3. Ensure that carburettor has sufficient petrol in float chamber to run engine.
4. Disconnect carburettor inlet pipe at carburettor and connect up a pressure gauge to disconnected pipe.

If a crimped type hose clamp is fitted it should be cut free and replaced with a screw type hose clamp. Fig. 4.

5. Check pump delivery pressure. Fig. 5

Start engine and record pressure at idle speed, momentarily race engine and again note pressure. Refer Fig. 5.

6. Disconnect gauge and reconnect carburettor inlet pipe.
7. Refit air cleaner assembly.
8. Remove fender covers and close bonnet.

FUEL PUMP — CLEAN

1. Open bonnet and fit fender covers.
2. Remove a single screw, lift off pump top, remove seal and withdraw filter from pump top.

3. Clean pump and filter.

4. Reassemble pump filter to pump cover and refit assembly to pump.

Ensure pump seal is not damaged and fits correctly into pump cover location, Fig. 6.

5. Remove fender covers and close bonnet.

FUEL PUMP — REMOVE AND INSTALL

To Remove

1. Open bonnet and fit fender covers.
2. Disconnect fuel pump inlet and outlet pipes.

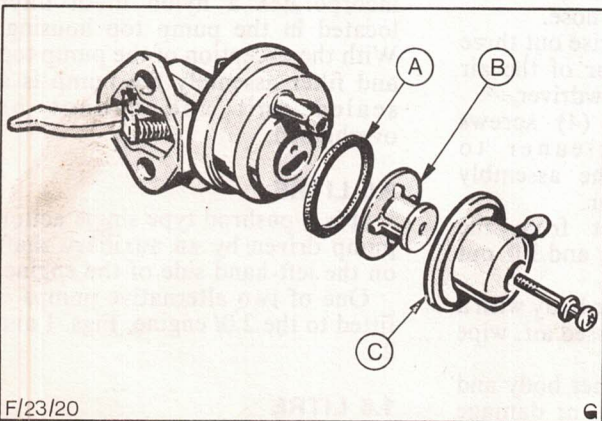

Fig. 3. Fuel pump assembly. 1.6 Litre.
A—Pump top.
B—Nylon mesh filter.
C—Seal.

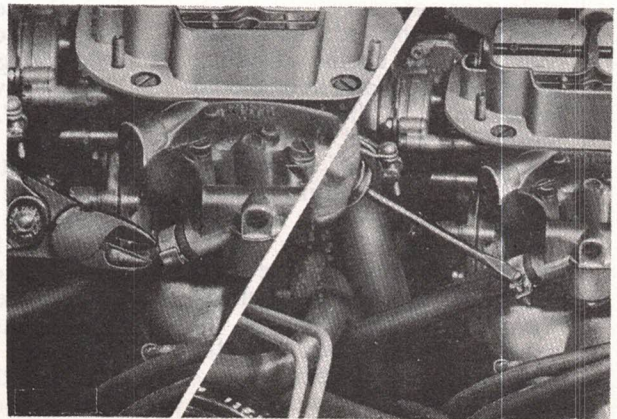

Fig. 4. Removal and reconnecting fuel inlet pipe.
A—Crimped type hose clamp.
B—Screw type hose clamp.
2.0/ shown.

If a crimped type hose clamp is fitted it should be cut free and replaced with a screw type hose clamp, Fig 7.

3. Remove two bolts and detach pump assembly.

To Install

4. Clean pump and block gasket faces.

5. Position pump with a new gasket and secure.

6. Reconnect inlet and outlet pipes.

7. Check operation.

8. Remove fender covers and close bonnet.

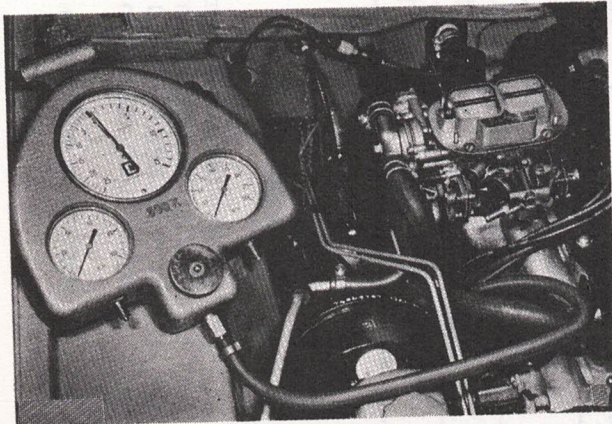

Fig. 5. Pressure gauge connected to fuel pump for pressure check.

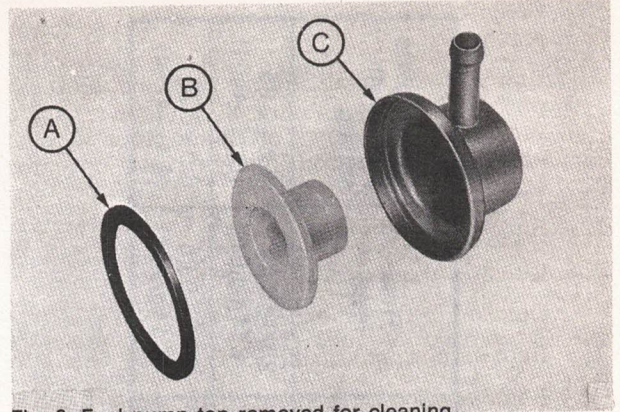

Fig. 6. Fuel pump top removed for cleaning.

- A—Fuel pump seal.
 - B—Fuel pump filter.
 - C—Fuel pump top.
- 1.6/ shown.

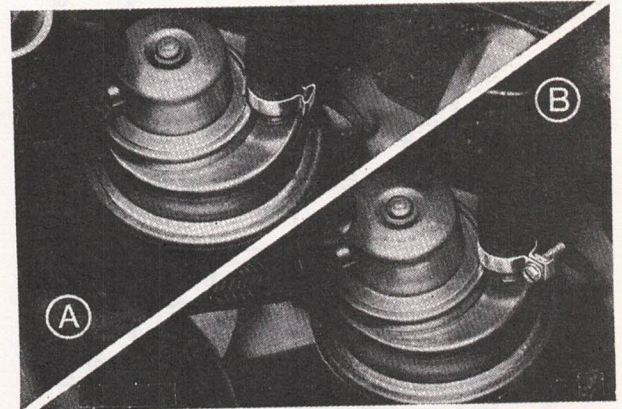

Fig. 7. Disconnecting and reconnecting fuel pump outlet.

- A—Crimped type hose clamp.
- B—Screw type hose clamp.

SPECIFICATIONS

WEBER CARBURETTOR 2.0 LITRE ENGINES

- Carburettor Model
- Throttle Barrel Diameter
- Venturi Diameter
- Main Jet
- Curb Idle Speed RPM
- Mixture % CO at Curb Idle (hot)
- Fast Idle RPM
- Float Level Upper
- Float Level Lower
- Choke Plate Pulldown Maximum
- Choke Phasing
- Choke Index Setting

- Brass Float
- Plastic Float
- Brass Float
- Plastic Float

All dimensions in millimetres.

Manual Trans

- 76HF/NB
- 32/36
- 26/27
- 132/130
- 800 ± 20
- 0.75 — 1.25
- 2200 ± 100
- 41.0 ± 0.5mm
- 35.3 ± 0.5mm
- 50.75 ± 1.0mm
- 45.0 ± 1.0mm
- 6.0 ± 0.25mm
- 2.0 ± 0.25mm
- 4.0 mm rich

Auto Trans

- 76HF/MA
- 32/36
- 26/27
- 132/137
- 800 ± 20
- 0.75 — 1.25
- 2100 ± 100
- 41.0 ± 0.5mm
- 35.3 ± 0.5mm
- 50.75 ± 1.0mm
- 45.0 ± 1.0mm
- 6.0 ± 0.25mm
- 2.0 ± 0.25mm
- 4.0 mm rich

(All dimensions in millimetres with inches in brackets)

MOTORCRAFT CARBURETTORS 1.6 LITRE ENGINE

Engine Part Number	Trans-mission Type	Throttle barrel diameter	Venturi diameter	Main jet	curb idle speed rev/min	at curb idle Mixture %CO (hot)	Fast idle rev. min	Float level	Choke plate pull down setting
1600 cc 761F-9510-KFA	MAN	36.0	28.0	137	800 ±20	0.5- 1.0	1100 ±100	29.0±0.25 (1.14±0.01)	3.8±0.25 (0.15±0.01)
1600 cc 761F-9510-KGA	AUTO	36.0	28.0	137	800 ±20	0.5- 1.0	1700 ±100	29.0±0.25 (1.14±0.01)	3.0±0.25 (0.12±0.01)

Auto choke — 1.6/ Auto — on index.
NOTE— All idle/co settings to be made with transmission in neutral.

AIRCLEANERS

Engine	Transmission	Part Number Prefix/Suffix	Type*	Control temperature
1600 (1V) OHV	Man Auto	76AA/AA 76AA/BA	T T	23°C(73°F)±2.3°C(4.0°F) 23°C(73°F) ± 2.3°C(4.0°F)
2.0/ (2V) OHC LC	Auto	76BA/AB	T	23°C(73°F)±2.3°C(4.0°F)
2.0/ (2V) OHC HC	Man	76BA/AB	T	23°C(73°F)±2.3°C(4.0°F)

* T = THERMOCONTROLLED

Fuel Tank

Capacity (usable) 53 litre

Carburettor

.. .. . See table

Fuel Pump

Type—OHV Mechanical driven from eccentric on camshaft

OHC

.. .. . Mechanical driven from eccentric on Aux. shaft.

Fuel Filter

.. .. . 21 to 35 kPa (3.0 - 5.0 lb./in.²)

Air Cleaner

Type Nylon mesh, located in fuel pump

.. .. . Paper element/thermo controlled.